

# MEDENUS

Gas Pressure Regulation



## Gas Filter DF 50

Product information



EN



# Table of contents

<b>Application, characteristics, technical data</b>	<b>4</b>
Application	4
Characteristics	4
Types of models / Options	4
Technical data	5
Structure and function	6
Installation example	6
Sectional view	6
<b>Dimensions, connection and weight</b>	<b>7</b>
<b>Types of models / Options</b>	<b>8</b>
<b>Volume flow diagram</b>	<b>9</b>
<b>Design</b>	<b>10</b>
<b>Order data</b>	<b>11</b>
<b>Contact</b>	<b>12</b>
<b>Notes</b>	<b>13</b>



## ATTENTION

Observe the following publications in relation to installation, start-up and maintenance:  
DVGW - work sheets G 491 and G 600  
Operating and Maintenance Instructions DF50

## List of abbreviations and formula symbols

AC	Accuracy class	$p_{ds\ o}$	Upper SSV response pressure	$W_{ds\ o}$	Upper spring adjustment range (SSV)
$AG_o$	Upper response pressure group	$p_{ds\ u}$	Lower SSV response pressure	$W_{ds\ u}$	Lower spring adjustment range (SSV)
$AG_u$	Lower response pressure group	$p_{f,max}$	Maximum closing pressure	$\Delta p$	Pressure difference from inlet pressure to outlet pressure
BV	Breather valve	PS	Maximum allowable pressure	$\Delta p_{wo}$	Min. re-engagement difference between upper response pressure and normal operating pressure
GPR	Gas pressure regulator	$p_u$	Inlet pressure	$\Delta p_{wu}$	Min. re-engagement difference between lower response pressure and normal operating pressure
HDS	High-pressure spindle	$Q_n$	Standard volumetric flow rate	$\rho_n$	Gas density
$K_G$	Valve flow rate coefficient	RE	Diaphragm assembly		
$p$	Pressure	RSD2	Throttle valve		
$p_d$	Outlet pressure	SSV	Safety shut-off valve		
$p_{df}$	SRV closing pressure	SRV	Safety relief valve		
$p_{do}$	SRV opening pressure	SG	Closing pressure group		
$p_{ds}$	Setpoint of the response pressure	$t_{Gas}$	Gas inlet temperature		
		VS	Valve seat		
		$w_d$	Outlet gas velocity		
		$w_u$	Inlet gas velocity		

# Application, characteristics, technical data

## Application

Type DF 50 filters are intended to separate gas impurities such as dust, rust, and other solids in gas-carrying line at a defined point. They are mainly used in gas systems and in front of such devices whose function is impaired by contamination.

These filters can be used for gases according to DVGW worksheet G 260/G 262 and for neutral non-aggressive gases. (other gases on request)

## Characteristics

- Easily replaceable filter cartridge
- High separation efficiency thanks to optimized flow guidance (30 µm standard, 5 µm optional)

## Type of models / Options (see page 8)

- Black epoxy resin coating
- Biogas & coke oven gas version (maximum 0.1% H<sub>2</sub>S)
- Flange sets for screw-in threads Rp1", Rp1.5", Rp2"

## Technical data

<b>Type</b>	DF 50
<b>Max. allowable pressure PS</b>	6 bar Rp 1/2" / 3/4" / 1" / 1 1/4" / 1 1/2" / 2" DN 40* / 50* / 65 / 80 / 100 / 125 / 150 2 bar DN 200 / 250 / 300
	* ) For screw-in units with flange set
<b>Nominal width</b>	Rp 1/2" / 3/4" / 1" / 1 1/2" / 2" DN 40* / 50* / 65 / 80 / 100 / 125 / 150 / 200 / 250 / 300

<b>Connection type</b>	Gas thread ISO 7-1 from Rp1/2 to Rp2 or ANSI-ASME B1.20 from 1/2"NPT to 2"NPT Flange PN16 – ISO 7005 from DN65 to DN300
------------------------	---

<b>Material</b>	Housing - Die-cast aluminum (up to DN100) - Sand-cast aluminum (from DN125) Filter - Non-woven polypropylene fibbers with metal supporting frame Seals - NBR
-----------------	--

<b>Temperature range</b> (operating/ambient temperature)	-40°C / +80°C (-40°F to +176°F)
---	---------------------------------

<b>Filtering area</b>	Rp 1/2" - 0.0055 m <sup>2</sup>	Rp 3/4" - 0.0055 m <sup>2</sup>	Rp 1" - 0.0145 m <sup>2</sup>
	Rp 2" - 0.0330 m <sup>2</sup>		
	DN 65 - 0.0535 m <sup>2</sup>	DN 150 - 0.154 m <sup>2</sup>	DN 300 - 0.420 m <sup>2</sup>
	DN 80 - 0.0535 m <sup>2</sup>	DN 200 - 0.276 m <sup>2</sup>	
	DN 100 - 0.0860 m <sup>2</sup>	DN 250 - 0.310 m <sup>2</sup>	

<b>Filtration efficiency</b>	Particle size > 30 µm (5 µm optional), filter class G4 to EN 779
------------------------------	--

<b>Function, strength, and tightness</b>	DIN 3386, DVGW work sheet G 498 and DIN 30690-1
--	---

<b>CE mark acc. to PED / PIN number</b>	PED/0497/2875/14
---	------------------

<b>Ex protection</b>	The mechanical parts of the device do not have any potential ignition sources of their own and therefore do not fall within the scope of ATEX 95 (94/9/EC). Electrical components fitted to the device comply with the ATEX requirements.
<b>Preferred installation position</b>	

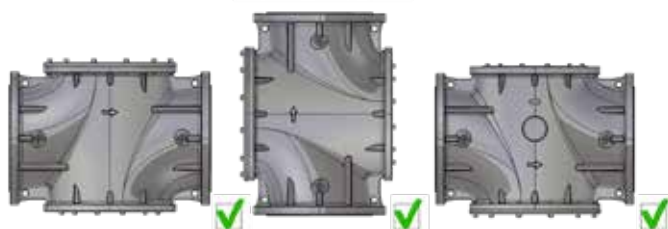

The installation position of the gas filters is freely selectable

Note: Observe the following documents in relation to installation, start-up, and maintenance:

- DVGW - work sheets G 491 and G 600
- Operating and Maintenance Instructions DF50



## Structure and function

The gas flows through the inlet flange into the filter housing. The dust particles entrained in the gas are retained by the filter element. The cleaned gas flows off through the outlet flange.

The filters mainly consist of the housing, the cover, and the filter cartridge. Taking off the cover for maintenance and replacement of the filter cartridge guarantees easy access. The filter cartridge is made of non-woven polypropylene fibers, is equipped with a metal support frame and is suitable for holding dust and other impurities with a size  $\geq 30 \mu\text{m}$  ( $\geq 5 \mu\text{m}$  optional).

If the dust holding capacity is exceeded or there is an excessive pressure difference, the filter loses its protective function. In this case, the filter element must be replaced.

## Installation example

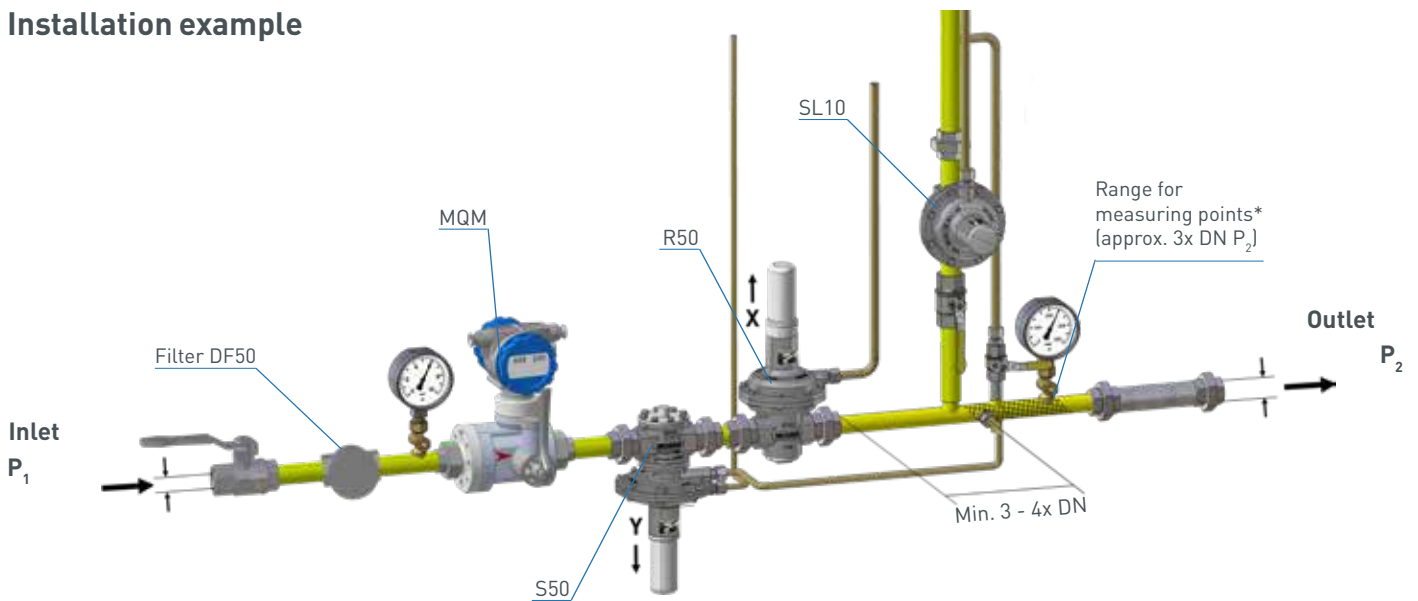

## Sectional view

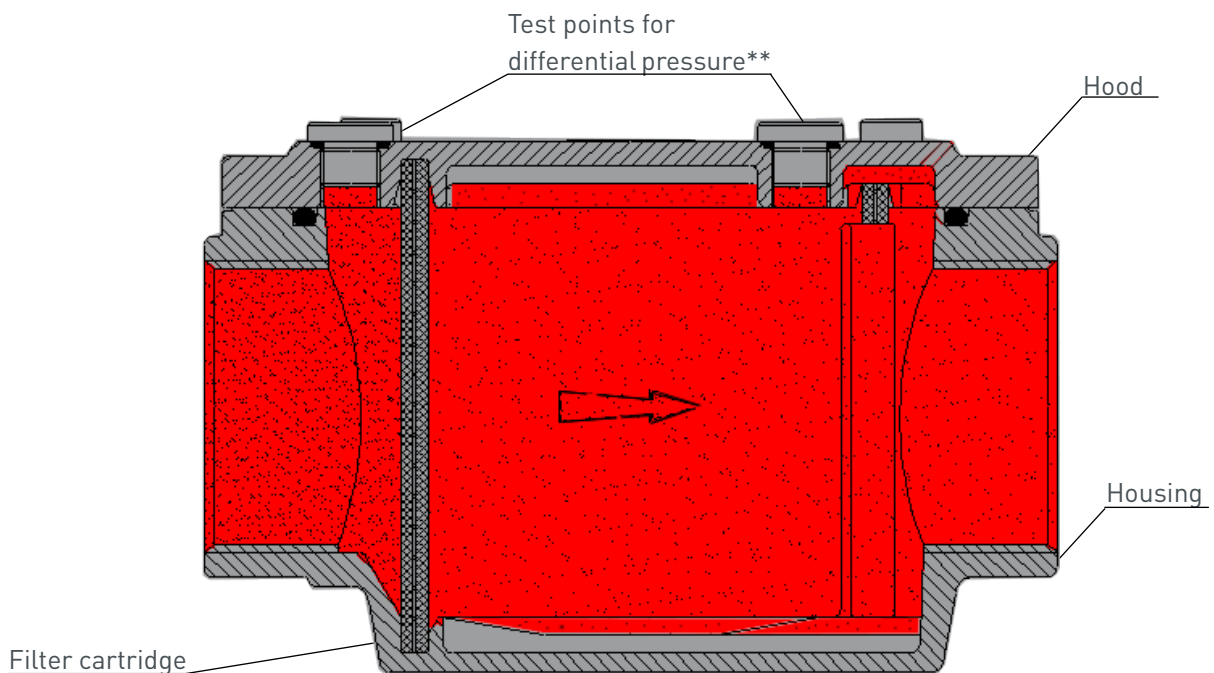

\*) Recommended max. velocity at the measurement line port 25 m/s

\*\*) Gauge connections (if available): G1/8" on models with RP thread and G1/4" on models with PN16 flange

## Dimensions, connection, and weight

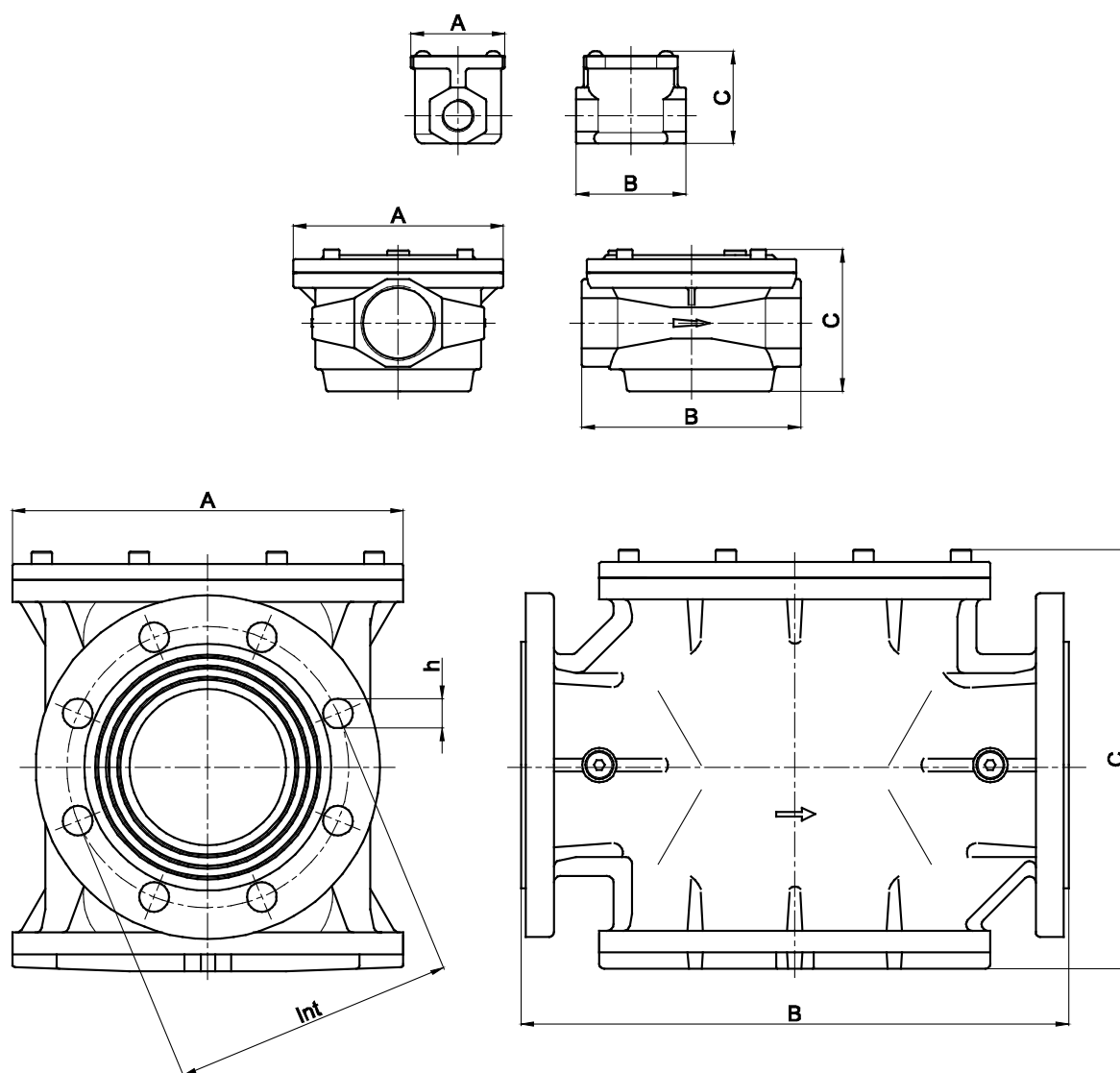

Nominal widths	DF50	DF50	DF50	DF50	DF50	DF50	DF50	DF50	DF50	DF50	DF50	DF50	DF50	DF50
	RP	RP	RP	RP	RP	RP	DN	DN	DN	DN	DN	DN	DN	DN
Dimensions	1/2"	3/4"	1"	1 1/4"	1 1/2"	2"	65	80	100	125	150	200	250	300
A [mm]	88	88	134	134	182	182	200	200	250	315	315	370	405	460
B [mm]	96	96	140	140	208	208	308	308	350	460	460	546	600	700
C [mm]	84	84	91	91	128	128	212	212	265	347	347	420	466	537
Int [mm]							145	160	180	210	240	295	355	410
h [mm]							4x18	8x18	8x18	8x18	8x23	12x23	12x28	12x28
Weight [kg]	0.39	0.38	0.97	0.85	2.2	2.0	8.5	8.4	13.5	22.8	24.5	47	69	96

## Types of models / Options

### Black epoxy resin coating

To protect the gas filters from influences in aggressive atmospheres.



---

### Types of models

- Biogas or coke oven gas version
- For screw-in filters with flange set DN25-DN50





# Volume flow diagram

- for natural gas ( $\rho_n = 0.83 \text{ kg/m}^3$ ;  $t = 15^\circ\text{C}$ )
- $\Delta p$  = pressure difference from inlet pressure to outlet pressure
- $Q_n$  = max. possible volume flow
- $f$  - natural gas L conversion factor

Gas	f	H <sub>s,n</sub> [kWh/m <sup>3</sup> ]	Gas	f	H <sub>s,n</sub> [kWh/m <sup>3</sup> ]
Acetylene	0.84	16.25	Sewage gas	0.84	
Ammonia	1.04	4.83	Carbon monoxide	0.81	3.51
Butane	0.55	37.23	Carbon dioxide	0.65	-
Chlorine	0.51	-	Air	0.80	-
Landfill gas	approx. 0.80		Methane	1.08	11.06
Natural gas L	1.00	9.77	Propane	0.64	28.03
Natural gas H	1.03	11.45	Oxygen	0.76	-
Ethane	0.78	19.55	Sulphur dioxide	0.53	-
Ethylene	0.97	16.516	Nitrogen	0.81	-
Mine gas (30% CH <sub>4</sub> )		0.86	Hydrogen	3.04	13.43
Helium	2.15	-			

Pressure loss in unpolluted state

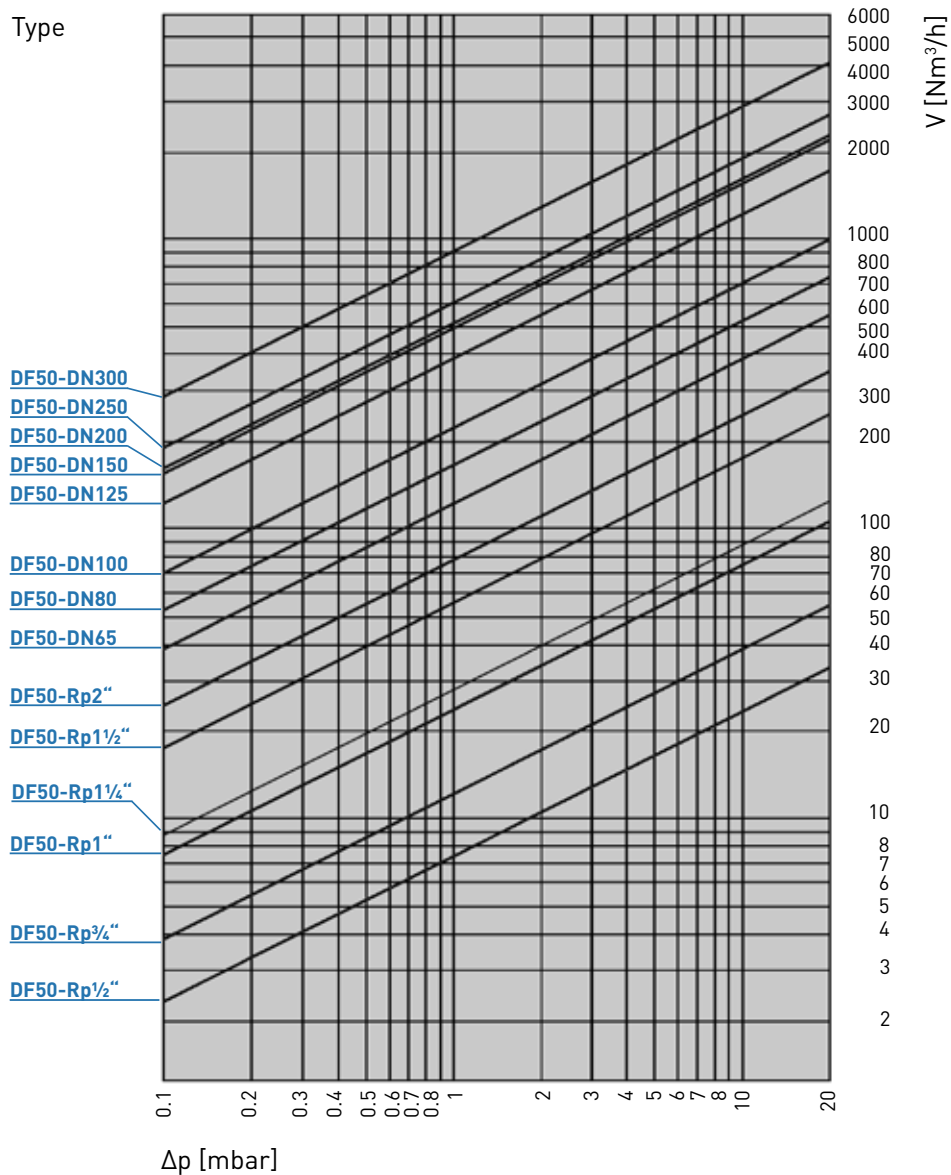

## Design

If the flow rate read from the diagram is based on the operating pressure instead of the pressure at standard conditions ( $p=1.01325$  bar,  $t=15^{\circ}\text{C}$ ), the pressure drop read from the diagram must be multiplied by the following factor:

$(1 + \text{relative pressure in bar})$

Example:

With a filter of size Rp1½" and an operating natural gas flow of 80 Nm<sup>3</sup>/h, the pressure drop according to the diagram is  $\Delta p = 2$  mbar. If this 80 Nm<sup>3</sup>/h flow is at 2 bar, then the effective pressure drop must be calculated as follows:

$$\Delta p = 2 \text{ mbar}^*) \times [(1 + 2) \times 1/\text{bar}] = 6 \text{ mbar}$$

\*) Determined from the diagram

The filter must be selected taking into account the following points:

- Pressure drop of  $\Delta p \leq 10$  mbar
- Flow rates  $w \leq$  at 20 m/s

## Order data

### Example:

Filter type: DF50/1"/6/WAZ/So

		Order code:				
		DF50	1"	6	WAZ	So
Order selection	Designation					
<b>Type</b>						
DF50	DF50	DF50				
<b>DN - Nominal width</b>	Table p. 7		1"			
<b>Max. operating pressure</b>						
2 bar	2					
6 bar	6			6		
<b>Acceptance test certificate to EN 10204/3.1</b>						
without acceptance test certificate	-					
with acceptance test certificate	WAZ				WAZ	
<b>Special model</b>						
- Black epoxy resin coating - Biogas or coke oven gas version - With flange set - 5 µm	So					So



## THE MEDENUS PLUS

### 10 reasons for good business relations

1. Consultancy expertise and quality standards developed over decades
2. Broad and proven standard range of feedback controllers
3. Modern, fast and efficient production for series products and for individual orders
4. Customer-specific design of pressure regulators and vacuum regulators and special designs
5. Guaranteed deadline compliance with a delivery deadline guarantee
6. Fast response time in all matters
7. Sufficiently large parts storage for production and spare parts
8. Customer-specific theory & practice training courses
9. Modular design right across the entire product range to facilitate optimized handling of spare parts
10. 100% Made in Germany

## Contact



Management  
ALEXANDER CHRISTIANI

Phone: +49 (0) 2761 / 82788-18  
Mail: a.christiani@medenus.de



Technical Inside Sales Department  
MINDAUGAS PECKAITIS

Phone: +49 (0) 2761 / 82788-23  
Mail: m.peckaitis@medenus.de



Head of Inside Sales Department  
MANUEL SCHEPP

Phone: +49 (0) 2761 / 82788-20  
Mobile phone: +49 (0) 170 / 6355309  
Mail: m.schepp@medenus.de



Inside Sales Department  
SEBASTIAN HUCKESTEIN

Phone: +49 (0) 2761 / 82788-11  
Mail: s.huckestein@medenus.de



Inside Sales Department  
STEFANIE MÜLLER

Phone: +49 (0) 2761 / 82788-13  
Mail: s.mueller@medenus.de



If you want to know more about solutions from MEDENUS for the gas industry, please contact your local contact person or go to our internet site at [www.medenus.de](http://www.medenus.de)

**Trade representation worldwide**  
[medenus.de/de/kontakt.html](http://medenus.de/de/kontakt.html)

## MEDENUS

Gas-Druckregeltechnik GmbH

Im Langen Feld 3  
D-57462 Olpe  
Phone: +49 (0)2761 82788-0  
Fax: +49 (0)2761 82788-9  
Mail: [info@medenus.de](mailto:info@medenus.de)  
**Internet: [www.medenus.de](http://www.medenus.de)**

## Notes

A series of horizontal dotted lines for taking notes, consisting of 25 rows.





**MEDENUS** Gas-Druckregeltechnik GmbH

Phone +49 (0)2761 82788-0

Fax +49 (0)2761 82788-9

Im Langen Feld 3 / D-57462 Olpe

[info@medenus.de](mailto:info@medenus.de)

[www.medenus.de](http://www.medenus.de)

**EN**