

# MEDENUS

Gas Pressure Regulation



## Safety Shut-Off Valve S 100



Operating and Maintenance Instructions

EN



# Design of the safety shut-off valve S 100

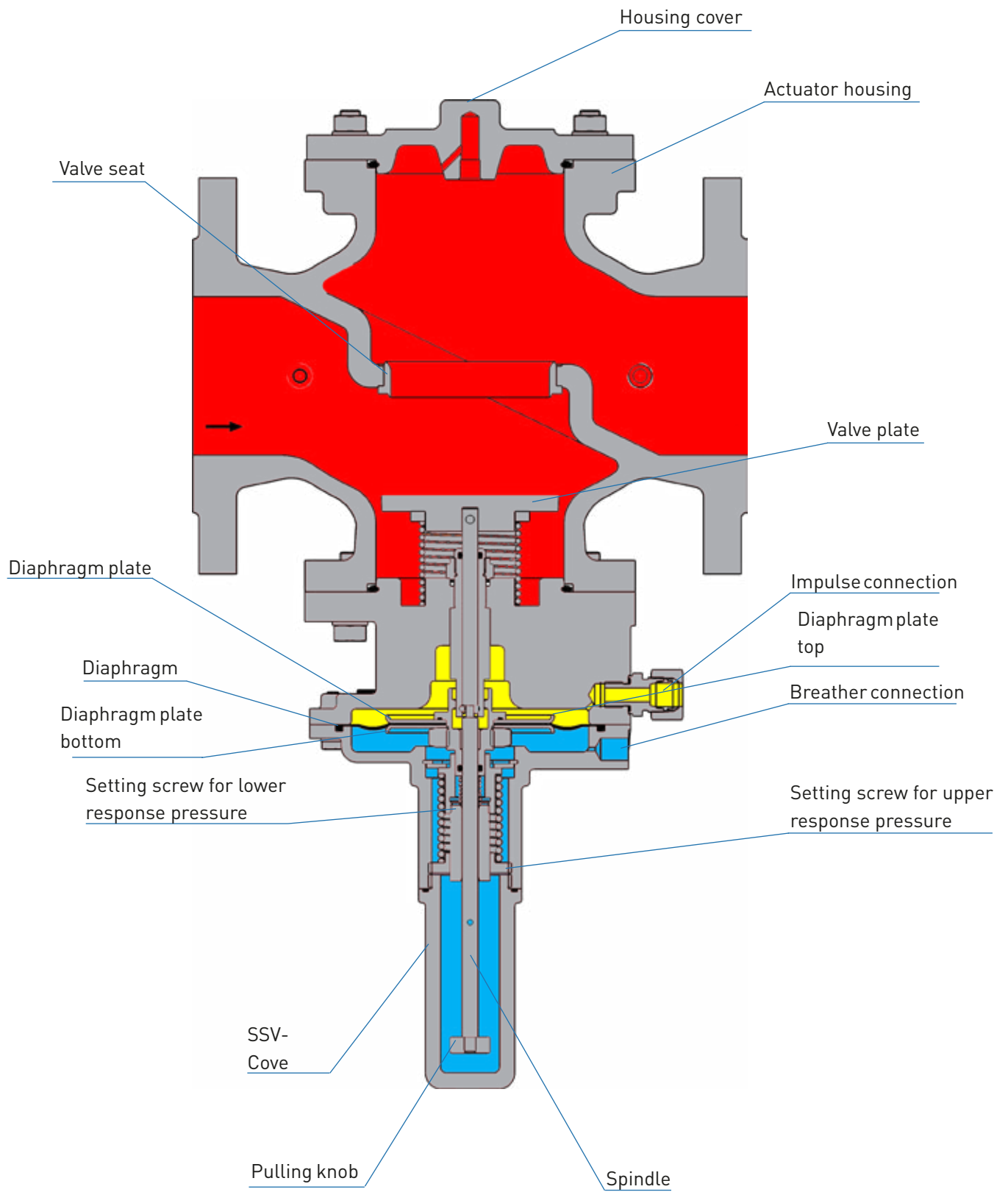

# Table of Contents

<b>1 General Information</b>	<b>6</b>
1.1 Warranty and Liability	6
1.2 Symbols, Notes	7
1.3 Terms, Abbreviations	7
<b>2 Application, Characteristics</b>	<b>8</b>
2.1 Application	8
2.2 Characteristics	8
2.3 Types of Models (Options)	8
<b>3 Avoidance of Foreseeable Misuse</b>	<b>8</b>
<b>4 Safety Instructions</b>	<b>9</b>
4.1 Hazards of Handling the Device	9
4.2 Personnel Requirements	9
4.3 Country-Specific Requirements	9
4.4 Handover of the Operating and Maintenance Instructions	9
4.5 Safety in Operation	10
4.6 What to Do in Case of Danger	10
<b>5 Responsibility of the Operator</b>	<b>10</b>
<b>6 Transport, Storage and Packaging</b>	<b>11</b>
6.1 Transport	11
6.2 Storage	11
6.3 Packaging	11
<b>7 Mounting and Commissioning</b>	<b>12</b>
7.1 Safety Instructions and Preparation	12
7.2 Mounting	12
7.3 Leakage Test (Test for External Leakage)	14
7.4 Initial Commissioning / Recommissioning	15
7.6 Decommissioning	18
<b>8 Maintenance</b>	<b>19</b>
8.1 Maintenance Plan	19
8.2 Maintenance Procedure	19
8.3 Table of Screw Tightening Torques $M_A$	20
8.4 Lubricants Table	20
8.5 Screw Retention	20
<b>9 Replacement and Disposal</b>	<b>20</b>
<b>10 Troubleshooting</b>	<b>21</b>
<b>11 Spare Parts</b>	<b>22</b>
11.1 Spare Part Drawing of Safety Shut-Off Valve SSV	22
11.2 Parts for Maintenance Work	23
Valve Plate SSV / Diaphragm SSV	23
O-Rings and Sealing Rings	23

---

<b>12 Accessories / Options</b>	<b>24</b>
12.1 AV 530 breather valve	24
12.2 Signal Transmitter / Reed Contact	25
12.3 SSV manual and remote release	28
<b>13 Tools</b>	<b>30</b>
13.1 SSV tightening tool	30
<b>Declaration of Conformity</b>	<b>31</b>

---

# 1 General Information

The personnel entrusted with installation, operation or maintenance of the safety shut-off valve must have completely read and understood beforehand the following documents:

- **Safety Shut-Off Valve S 100 Product Information**  
The product information contains technical data, dimensions and a description of the design and the mode of operation.
- **Safety Shut-Off Valve S 100 Operating and Maintenance Instructions**  
This document allows safe and efficient handling of the device and contains information on assembly, commissioning, maintenance, troubleshooting, and repair according to regulations.  
It is an integral part of the scope of delivery of the device, must be kept in close proximity of the device and must be readily accessible to personnel at any time.  
The basic prerequisite for safe working is compliance with all safety instructions and instructions for action given in this manual. Accordingly, the information and instructions must be observed when working on the device or on the gas line. In addition, the local occupational safety regulations and general safety regulations for the application range of the device shall apply.  
The figures in these instructions are provided for basic understanding and may differ from the actual design. The contents of these instructions are protected by copyright. They may be used as part of operating the device. Any other use and/or reproduction is not permitted without prior authorization by MEDENUS Gas-Druckregeltechnik GmbH.

## 1.1 Warranty and Liability

Claims under warranty or liability for personal injury and material damage are generally void **if** one or several of the following **conditions are not observed**:

- Work on the device during the warranty period may only be performed in consultation with the manufacturer
- Designated use of the device in accordance with the established conditions of use
- Proper installation, commissioning, operation and maintenance of the device
- Operation of the device with properly installed and functioning safety devices only
- Operating and maintenance instructions of the device or of the system
- Compliance with the maintenance instructions
- Properly performed repairs
- Supply lines without defects
- The use of original MEDENUS® spare parts and lubricants listed in these instructions or
- Force majeure

### It is generally prohibited

- To perform constructive modifications on the device
- To keep using the device despite the detection of a defect

## 1.2 Symbols, Notes

The instructions contain safety instructions marked with symbols to indicate possible consequences in case of non-observance:

This combination of symbol and signal word indicates a potentially hazardous situation which, if not avoided, may result in minor or moderate injury, damage to the device, the breakdown of the system, and material or environmental damage.



**ATTENTION**

This combination of symbol and signal word indicates an imminent hazardous situation which, if not avoided, will result in death or serious injury.



**DANGER**

This signal word highlights useful tips, recommendations, and information for efficient and trouble-free operation.

**Note**

## 1.3 Terms, Abbreviations

Terms and abbreviations are explained below:

ATC	Acceptance test certificate	MOP	Maximum operating pressure in a system	$p_{ds}$	Setpoint of the outlet pressure
DN	Nominal width	$p_d$	Outlet pressure	SSV	Safety shut-off valve
GPR	Gas pressure regulator				
$M_A$	Screw tightening torque				

## 2 Application, Characteristics

### 2.1 Application

Safety shut-off valve (SSV), direct-acting (operating without auxiliary power), for systems acc. to DVGW work sheets G 491 (A) and G 600 (A) (TRGI)

Can be used as an equipment component on gas consumption facilities as defined in Regulation (EU) 2016/426.

Can be used for the gases defined in DVGW work sheets G 260 / G 262 and neutral non-aggressive gases. (other gases on request)

### 2.2 Characteristics

- Integral pressure-tight model (IS)
- High flow rate capacity
- Open-air model

### 2.3 Types of Models (Options)

- With BV breather valve
- With RSS switching valve (SSV diaphragm rupture protection)
- With electric position indicator SSV "Closed" via inductive proximity initiator or via reed contact
- With SSV manual release
- With SSV electromagnetic remote release when power is applied or in case of power failure
- Oxygen model

## 3 Avoidance of Foreseeable Misuse

- The SSV must not be used to control liquids.
- The SSV must not be used in temperature ranges below -20 °C or above 60 °C.
- The SSV must not be used for pressure ranges higher than the pressure "PS" indicated on the nameplate.
- The SSV may only be used for the gases specified under item 2.1 Application in these operating instructions. Other gases, such as oxygen or hydrogen, must be explicitly stated on the nameplate. Please consult the manufacturer before use.
- The SSV must not be used in high-temperature areas (HTB) without an upstream HTB fuse.

## 4 Safety Instructions

National accident prevention regulations and the system operator's safety regulations are not superseded by these operating and maintenance instructions and must be taken into consideration with priority (in Germany, see, among others, DVGW work sheets G 600, G 459/II, G 491 and G 495).

When performing work on the device, the current general and specific safety regulations must be observed.

The application limits of the device with respect to the medium, operating pressure and operating temperature can be found on the nameplate affixed to the device or on the acceptance test certificate.

Using the device under different operating conditions must be agreed upon in consultation with MEDENUS Gas-Druckregeltechnik GmbH.

The mechanical components of the device do not have any potential ignition sources of their own nor any hot surfaces and are thus not covered by the scope of 2014/34/EU (ATEX). The electronic accessories used comply with the ATEX requirements.

### 4.1 Hazards of Handling the Device

MEDENUS® devices conform with current standards and directives, the recognized technical rules and the recognized safety rules.

However, improper use can result in hazards to the user or to third parties. This can also result in damage to the device or to the system.

This is why the device may only be used:

- in accordance with its designated use
- in perfect condition
- while observing the notes given in these operating and maintenance instructions, and inspection and maintenance regulations, which apply to the functioning and safety of the overall system.

Malfunctions or faults must be eliminated immediately.

### 4.2 Personnel Requirements

The device may only be mounted by qualified personnel.

Only authorized personnel with the required qualification is allowed to perform settings or repairs on the device.

### 4.3 Country-Specific Requirements

The rules and regulations applicable at the place of use with respect to

- gas lines, installation of the gas system,
- gas supply,
- work on the gas system,
- accident prevention.

### 4.4 Handover of the Operating and Maintenance Instructions

The supplier of the system shall hand over these operating and maintenance instructions to the operator of the system no later than during commissioning and training of the operating personnel with the reminder to carefully store these instructions.

## 4.5 Safety in Operation

The device may only be used when all protective devices on the device or in the system are fully functional.

The device must be inspected by a representative of the manufacturer or by a qualified person for externally visible damage and for proper functioning at least once a year.

A more frequent inspection may become necessary, depending on the system conditions.

## 4.6 What to Do in Case of Danger

Information on what is to be done in case of danger and in case of accidents can be found in the respective operator's or specialist companies' work instructions.

## 5 Responsibility of the Operator

**Operator** An operator is a person who operates the device himself/herself for commercial or economic purposes or leaves it to a third party for use/application and is legally responsible for the safety of the user, the personnel or third parties during operation.

**Operator duties** The device is used in the commercial sector. The operator of the device is therefore subject to the legal obligations for occupational safety. In addition to the safety instructions contained in these instructions, the established maintenance intervals must be observed, taking into account the respective national standard (alarm and hazard prevention plan).

In particular, the following applies:

- The operator is obliged to perform work on MEDENUS® devices during the warranty period only after consultation with the manufacturer. Otherwise the claims under warranty will become void.
- The operator must obtain information on the current occupational safety regulations and determine additional hazards resulting from the special work conditions at the place of use of the device in a risk assessment. The owner must implement the results in the form of operating instructions for the device.
- During the entire time of use of the device, the operator must check whether the operating instructions issued by him/her conform to the current state of the regulations and, if necessary, adapt them.
- The operator must clearly regulate and define the responsibilities for installation, operation, troubleshooting, maintenance and cleaning.
- The operator must ensure that all persons handling the device have read and understood these instructions. In addition, the operator must train the personnel at regular intervals and inform them about the hazards.
- The operator must make available to the personnel the required protective equipment and oblige them to wear the required protective equipment.
- Moreover, the operator is responsible for the device always being in technically perfect condition.

Therefore, the following applies:

- The operator must make sure that the maintenance intervals described in these instructions are observed.
- The operator must have all safety devices checked regularly for functionality and completeness.

## 6 Transport, Storage and Packaging

### 6.1 Transport

#### Note

The device is delivered with flange protection caps. They must be removed prior to installation. Make sure that the device is transported horizontally using suitable lifting gear. The device must be handled carefully and secured against impacts and knocks.

In case of transport damage, we will require the following information from the nameplate affixed to the device:

- Device type
- Device model
- Year of construction/fabrication number

### 6.2 Storage

**Equipment and spare parts must be stored under the following conditions:**

- Do not store outdoors.
- Store in a dry and dust-free location.
- Store on a flat surface.
- Do not expose to aggressive media.
- Do not expose to ozone or ionizing radiation.
- Do not store adjacent to direct heat sources.
- Avoid mechanical vibrations.
- Storage temperature: 0 to 25 °C.
- Relative air humidity: < 55 %.

**Spare parts:**

- Components susceptible to corrosion must be provided with a suitable preservative.
- Do not store O-rings and seals for more than 5 years even if stored properly.
- Spare parts must be stored in their original packaging until use.

**Storage period for devices:**

- Storage of the device for up to one year:  
Store the device in its original packaging and its original condition at the time of supply. All protective caps of the device must remain mounted.
- Storage of the device for more than 1 year (e.g. as a spare device):  
Store the device in its original packaging and its original condition as delivered and check it for damage once a year. Check the housing surface for dirt, damage and corrosion. If necessary, clean all external parts. After 5 years, all O-rings and seals must be replaced.

### 6.3 Packaging

- The individual packaged items have been packaged in view of the transport conditions to be expected.
- The symbols on the packaging must be observed during transport and storage.
- Only environmentally friendly materials have been used for packaging.
- The packaging is designed for protecting the individual components from transport damage, corrosion and other damage until mounting. This is why the packaging must not be destroyed and only removed just prior to mounting.

# 7 Mounting and Commissioning

## 7.1 Safety Instructions and Preparation

Prior to starting work on pressurized components:

- Close all connections to the gas line.
- Depressurize all pressurized components. Also discharge residual energies.
- Defective components charged with pressure in operation must be replaced immediately by an appropriate expert.

**DANGER**



Prior to starting work, ensure sufficient clearance for mounting.

Before installing the device, check whether the performance data (nameplate) and the scope of delivery coincide with the order or the system data, i.e., make sure that the provided devices are suitable for their intended purpose. In particular, the inlet pressure of the system must be lower than the maximum allowable pressure of the device.

**Note**

Direct contact of gas valves and fittings, i.e., the control system, with hardening masonry, concrete walls or floors is not permitted. Provide suitable supports, working materials and protective equipment.

**Note**

Take into account the minimum clearances for maintenance as stated in the product information.

Before installing the device in the pipeline, check whether a shut-off device that interrupts the gas flow supply to the device has been mounted upstream and downstream of the device to be installed.

Prior to commissioning, make sure that all installation work has been carried out and completed in accordance with the data and information given in these instructions and that no unauthorized persons stay in the danger zone.

**DANGER**



## 7.2 Mounting

- Remove the packaging, flange protection caps and shipping braces.
- Check the device for wear and damage.
- Make sure that the device is installed free of stress (see DVGW info gas no. 19).  
Make sure to observe the direction of flow i.e., the arrow on the housing must point in the direction of flow.
- All breather lines (items 7.04 / 7.07) must be vented to the outside atmosphere.
- The breather line (item 7.04) may not be required if breather valves are used.
- The measuring lines (items 7.05 / 7.08) must be connected in a pipeline section with a steady flow. There must be no installations that cause flow interference such as shutters, expansions, manifolds, junctions, isolation valves etc. directly upstream and downstream of the measurement point.

**Note  
Note**

**Note**

### Tightening torques $M_A$ \*)

Gas pressure regulators		Flange tightening torques	
Screw size	Screw tightening torque $M_A$	Screw size	Screw tightening torque $M_A$
M6	8 Nm	M12	60 Nm
M8	18 Nm	M16	120 Nm
M10	36 Nm	M20	190 Nm
M12	62 Nm		

\*) For the assembly of the flange connections, the maximum torques specified by the flange and gasket manufacturers must be observed. The values indicated here should be considered as approximate values.

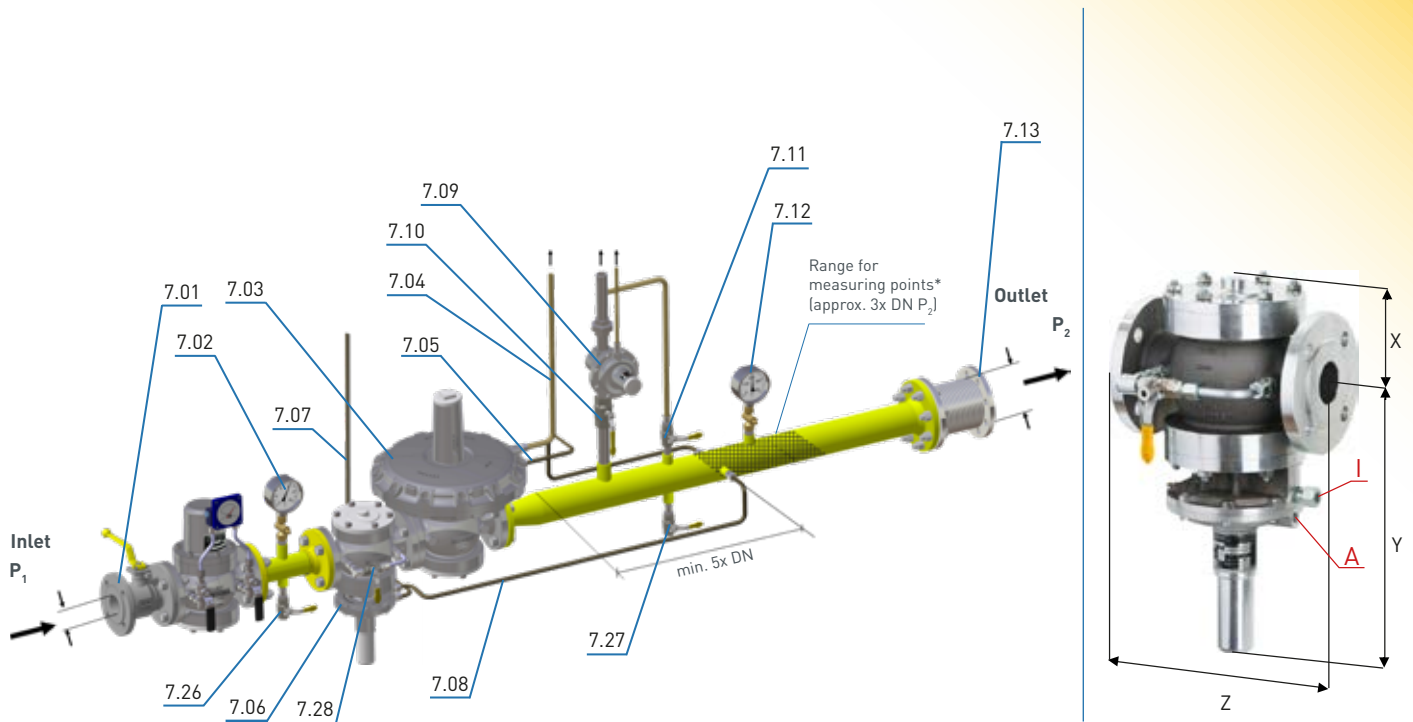

- The maximum flow rate at the measuring point must not exceed 25 m/s, depending on the system conditions.
- In certain system circuits, such as gas control systems for gas motors and in gas burners, higher flow rates than 25 m/s are also possible. Please contact us.
- The measuring line must be connected to the pipeline separately, laterally or at the top for each device (1 gas pressure regulator (item 7.03); 1 SSV (item 7.06)).
- The SSV measuring line (item 7.08) must always be connected upstream of the first shut-off valve (item 7.13) on the outlet side in such a way that it cannot be shut off.
- The SSV (item 7.06) can be rotated to any position.

## Connection

Nominal width	Version	Bore Ø [mm]		Impuls- leitung / impulse line (I)	Atmungs- leitung / breathing line (A)
		Impuls- leitung / impulse line (I)	Atmungs- leitung / breathing line (A)		
DN 025 DN 040	MD	2	2	Connection* for: tube 12 x 1.5 (thread G 1/4)	
	MD-R	2	3		
	HD	2	2		
DN 050	MD	2	2		
	MD-R	2	3		
	HD	2	2		
DN 065	MD	3.5	2		
	MD-R	3.5	3		
	HD	3.5	2		
DN 080 DN 100 DN 125	MD	2	2		
	MD-R	2	3		
	HD	2	2		
DN 150	MD	4	2	Connection* for: tube 12 x 1.5 (thread G 3/8)	
	MD-R	4	2		
	HD	4	2		
DN 200	MD	4	2		
	MD-R	4	2		
	HD	4	2		

## 7.3 Leakage Test (Test for External Leakage)

The devices are subjected to a strength and leakage test ex works at MEDENUS Gas-Druckregeltechnik GmbH.

The leakage test in the fully assembled system must be performed prior to commissioning and following maintenance work.

For the external leakage test in the fully assembled system, the following applies

### For Germany:

According to DVGW work sheet G 491, the fully assembled system must be subjected to a leakage test with air or an inert gas at the installation site, using 1.1 times the maximum operating pressure of the system (MOP).

An exception is the room between the actuator and the first shut-off valve on the outlet side. This room must be checked using the test pressure corresponding to the maximum permissible pressure in the system in case of a malfunction (1.1 MOP<sub>p</sub>). In this test, all detachable connections must be checked using a foaming agent.

### For other countries:

The relevant national and international standards shall apply.

### Procedure

- Close the ball valve upstream of the valves and fittings (item 7.01).
- Close the downstream shut-off devices (item 7.13) (ball valve, solenoid or pneumatic valve).
- Depressurize the system (item 7.11).
- If there is a SRV (safety relief valve) in the controlled section and the test pressure is higher than the relief pressure of the SRV (item 7.09), the line upstream of the SRV (item 7.10) must be closed.
- Connect the testing device to measuring points upstream and downstream of the gas pressure regulator (items 7.26 / 7.27).
- Always increase the test pressure slowly and steadily.

### While doing so, you must ensure:

Pressure in outlet chamber (item 7.12)  $\leq$  pressure in inlet chamber (item 7.02)

Pressure build-up always from the inlet side (inlet chamber)

Pressure reduction always from the outlet side (outlet chamber)

- After leakage test:  
Open the ball valve in the SRV line (item 7.10) again.

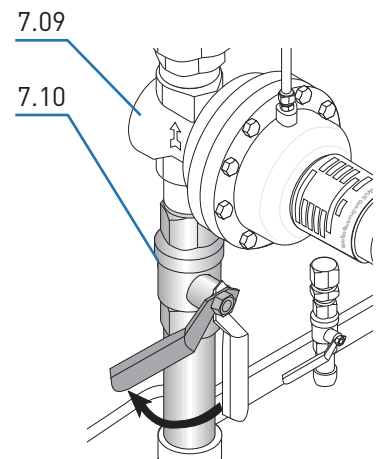

### Note

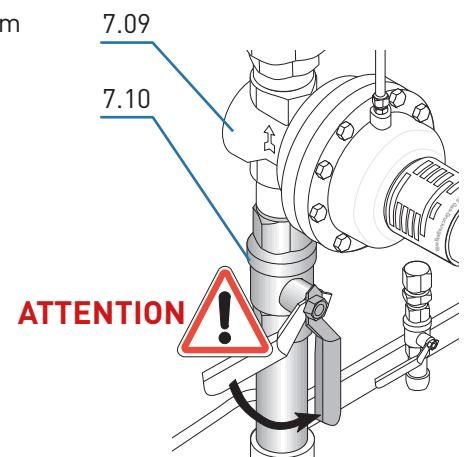

## 7.4 Initial Commissioning / Recommissioning

Initial commissioning of the system components shall be carried out by the operator. For commissioning, please refer to the documents listed under item 1 "General Information" and the system operator's work instruction.

The devices delivered by MEDENUS Gas-Druckregeltechnik GmbH are factory-set to the operating data specified by the customer. This data is listed on the Acceptance Test Certificate (ATC)\* and the type plate.

Prior to commissioning the system, a functional test must be performed on the gas pressure regulator (GPR) and the safety shut-off valves.

### Note

#### Procedure

- Close the ball valve upstream of the valves and fittings (item 7.01).
- Close the downstream shut-off devices (item 7.13) (ball valve, solenoid or pneumatic valve).
- Depressurize the system (item 7.11).
- Close the venting ball valve (item 7.11).
- Slowly open ball valve upstream of the valves and fittings (item 7.01).

If the inlet shut-off device is equipped with a bypass, the latter must be slowly opened for pressure compensation as step 1. This is followed by slowly opening the inlet shut-off valve which will close the bypass. The same is true of the outlet shut-off valve.

### Note

- Check the inner leakage of the SSV (item 7.06) by reading the pressure gauge installed downstream of the GPR (item 7.12).
- Unscrew the sealing cap (item 7.15) of the safety shut-off valve (SSV).
- Perform pressure compensation by opening the ball valve (item 7.28) and engage the SSV by pulling the pull knob (item 7.14).
- The ball valve (item 7.28) automatically closes after being released.
- A closing pressure corresponding to the set value is established on the GPR.

An SSV with underpressure shut-off can only be engaged if the pressure at the measuring point exceeds the set value by at least the re-engagement differential.

### Note

- Testing the response pressure of the SSV by slowly increasing or decreasing the output pressure to response pressure.
- It may be necessary to correct the setpoint values of the response pressures. This is done by turning the SSV setpoint setting screws (items 7.17 / 7.19) to the right (pressure increase) or left (pressure decrease) in order to increase/decrease the setpoint value.

The inner setting screw (item 7.17) sets the underpressure shut-off level (lower trigger level) and the outer setting screw (item 7.19) sets the upper trigger level.

### Note

- Perform pressure compensation again by opening the ball valve (item 7.28) and engage the SSV by pulling the pull knob (item 7.14).
- Close the ball valve (item 7.28) again.

\*) Acceptance Test Certificate (ATC) available optionally

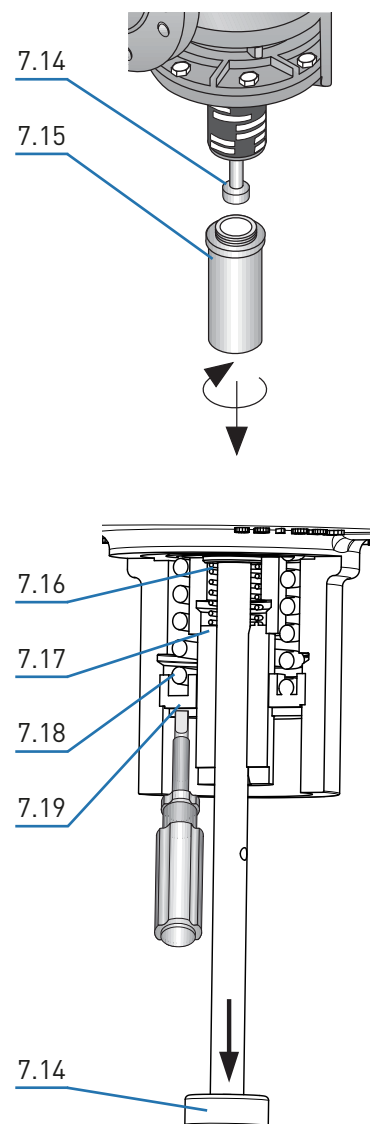

## Changing the control range

Switching to the control range of a different setpoint spring can be done for the SSV while the device is pressurized.

- Remove the sealing cap (item 7.15) and screw off the pull knob (item 7.14) for changing the spring of the underpressure shut-off device (item 7.16).
- Screw off the corresponding setting screw (items 7.17 / 7.19) for the upper or lower trigger level.
- Pull out the spring (item 7.16 / 7.18) and replace it with one that fits.
- Screw in the setting screw (item 7.17 / 7.19) again and fasten the pull knob (item 7.14) on the spindle again.
- Set the desired setpoint and screw on the sealing cap (item 7.15).

Note

The SSV closes if the overpressure setpoint spring (upper trigger level) is removed from a pressurized system.

Note

## 7.5 SSV Setpoint Spring Table - Control Device

		RS 250: DN 25 - 100 / RS 251: DN 50 - 80							
		small ball lock							
		ND				MD			
		to $W_{ds\ o}$ 200mbar				to $W_{ds\ o}$ 300mbar			
Spring data		Lower response pressure		Upper response pressure		Lower response pressure		Upper response pressure	
Feder Nr.	Farbe [RAL]	$W_{ds\ u}$ [mbar]	$\Delta p_{wu}$ [mbar]	$W_{ds\ o}$ [mbar]	$\Delta p_{wo}$ ** [mbar]	$W_{ds\ u}$ [mbar]	$\Delta p_{wu}$ [mbar]	$W_{ds\ o}$ [mbar]	$\Delta p_{wo}$ ** [mbar]
FE 900	1028	1 - 3	15			1 - 8	20		
FE 901 VA	2002	4 - 6	15			6 - 17	20		
FE 902 VA	6010	5 - 15	15			12 - 24*	20		
FE 903	5015	10 - 17	15			22 - 40	20		
FE 904 VA	9005	12 - 19	15			30 - 50	20		
FE 905 VA	9010	20 - 25	15			45 - 70	20		
FE 906	4002					65 - 100	20		
FD 910	1028			8 - 17	15			20 - 40	20
FD 911	2002			20 - 30	15			35 - 70	20
FD 912	6010			30 - 55	15			65 - 110	20
FD 913	5015			44 - 74	15			100 - 160	20
FD 914	9005			63 - 110	15			150 - 235	20
FD 915	9010			99 - 178	15			225 - 300	20
FD 916	3050			157 - 200	15				
FD 917	5010								
FD 918	9006								
FD 919	4002								

RS 250: DN 25 - 100 / RS 251: DN 50 - 80									
small ball lock									
MD-R					HD				
to $W_{ds_o}$ 3500mbar					to $W_{ds_o}$ 8000mbar				
Spring data		Lower response pressure		Upper response pressure		Lower response pressure		Upper response pressure	
Feder Nr.	Farbe [RAL]	$W_{ds_u}$ [mbar]	$\Delta p_{wu}$ [mbar]	$W_{ds_o}$ [mbar]	$\Delta p_{wo}^{**}$ [mbar]	$W_{ds_u}$ [mbar]	$\Delta p_{wu}$ [mbar]	$W_{ds_o}$ [mbar]	$\Delta p_{wo}^{**}$ [mbar]
FE 900	1028	35 - 50	50			120 - 180	500		
FE 901 VA	2002	50 - 80*	50			150 - 280*	500		
FE 902 VA	6010	70 - 105	50			280 - 480	500		
FE 903	5015	100 - 140	50			330 - 500	500		
FE 904 VA	9005	110 - 160	50			400 - 550	500		
FE 905 VA	9010	150 - 205	50			550 - 800	500		
FE 906	4002	200 - 300	50			800 - 1200	500		
FD 910	1028			90 - 125	50				
FD 911	2002			120 - 210	50				
FD 912	6010			200 - 330	50				
FD 913	5015			285 - 460	50				
FD 914	9005			450 - 680	50				
FD 915	9010			640 - 1040	50			2200 - 4000	300
FD 916	3020			1030 - 1480	50			3400 - 4750	300
FD 917	5010			1450 - 2200	50			4700 - 7400	300
FD 918	9006			1900 - 3500	50			7200 - 8000	300
FD 919	4002				50				

\*) Standard spring

\*\*) If the control device is set up for simultaneous monitoring of upper and lower response pressures, the difference between the setpoints for the upper and lower response pressures ( $p_{ds_o}$  and  $p_{ds_u}$ ) should be at least 10% greater than the total of values given for  $\Delta p_{wo}$  and  $\Delta p_{wu}$ .

RS 250: DN 150 - 200 / RS 251: DN 100									
large ball lock									
ND					MD				
to $W_{ds\ o}$ 200mbar					to $W_{ds\ o}$ 300mbar				
Spring data		Lower response pressure		Upper response pressure		Lower response pressure		Upper response pressure	
Feder Nr.	Farbe [RAL]	$W_{ds\ u}$ [mbar]	$\Delta p_{wu}$ [mbar]	$W_{ds\ o}$ [mbar]	$\Delta p_{wo}$ [mbar]	$W_{ds\ u}$ [mbar]	$\Delta p_{wu}$ [mbar]	$W_{ds\ o}$ [mbar]	$\Delta p_{wo}$ [mbar]
FM 400	1028	2 - 25	20			10 - 40*	20		
FM 402	6010					35 - 115	20		
FM 404	9005					60 - 245	20		
FL 411	3002			28 - 76	20				
FL 412	6010			48 - 114	20			40 - 180	20
FL 413	5015			93 - 200	20			70 - 300	20
FL 415	9010								
FL 417	4010								

RS 250: DN 150 - 200 / RS 251: DN 100									
large ball lock									
MD-R					HD				
bis $W_{ds\ o}$ 3500mbar					bis $W_{ds\ o}$ 8000mbar				
Spring data		Lower response pressure		Upper response pressure		Lower response pressure		Upper response pressure	
Feder Nr.	Farbe [RAL]	$W_{ds\ u}$ [mbar]	$\Delta p_{wu}$ [mbar]	$W_{ds\ o}$ [mbar]	$\Delta p_{wo}$ [mbar]	$W_{ds\ u}$ [mbar]	$\Delta p_{wu}$ [mbar]	$W_{ds\ o}$ [mbar]	$\Delta p_{wo}$ [mbar]
FM 400	1028	20 - 180*	50			0 - 250	500		
FM 402	6010	155 - 380	50			150 - 1000*	500		
FM 404	9005	200 - 950	50			650 - 2050	500		
FL 411	3002								
FL 412	6010			145 - 670	50			380 - 1400	300
FL 413	5015			270 - 1230	50			800 - 2800	300
FL 415	9010			1200 - 3500	50			3200 - 5500	300
FL 417	4010							4500 - 8000	300

### Determining the upper response pressure

Outlet pressure $P_d$ (mbar)	Upper response pressure $W_{ds\ o}$ ***
$\leq 200$	$P_d + 100$ mbar
$> 200 - \leq 800$	$P_d \times 1.5$
$> 800 - \leq 1600$	$P_d \times 1.3$
$> 1600$	$P_d + 500$ mbar

\*) if possible not greater than 500 mbar

\*\*) If the control device is set up for simultaneous monitoring of upper and lower response pressures, the difference between the setpoints for the upper and lower response pressures ( $p_{ds\ o}$  and  $p_{ds\ u}$ ) should be at least 10% greater than the total of values given for  $\Delta p_{wo}$  and  $\Delta p_{wu}$ .

\*\*\*) The upper response pressure is rounded up to full tens, for example 251 mbar -> 260 mbar

## 7.6 Decommissioning

For decommissioning, please refer to the documents listed under item 1 "General Information" and the system operator's work instruction.

### Procedure

- Slowly close the outlet shut-off valve (item 7.13)
- Close the ball valve upstream of the valves and fittings (item 7.01).
- Depressurize the system (item 7.11).
- Close the venting ball valve (item 7.11).

## 8 Maintenance

### 8.1 Maintenance Plan

The following sections describe the maintenance work required for optimal and trouble-free operation of the device. If increased wear is detected during regular inspections, the required maintenance intervals must be shortened in accordance with the actual wear.

For any questions on maintenance work and intervals, please contact the manufacturer.

The intervals for monitoring and maintenance work are strongly dependent on the operating situation and the condition of the gas. This is why no fixed intervals can be given. For Germany, it is recommended that the maintenance periods as specified in DVGW work sheet G 495 are observed initially. For each system, this must be followed by determining the maintenance interval independently on a medium-term basis.

During maintenance work, the components must be cleaned and subjected to a thorough visual inspection. This is also necessary if irregularities in the operating behavior have been detected during operation or during functional tests. The check must cover the diaphragms and sealings in particular.

Damaged parts and O-rings dismantled during dismantling must be replaced with new ones.

It is recommended to stock the parts listed in chapter 11.2 for maintenance work.

Interval	Maintenance work	Personnel
According to the data given in DVGW work sheet G 495 or when required	Replacing O-rings	Qualified person
	Replacing diaphragms	
	Replacing the valve plate	
	Replacing sealing rings for the connections of the breather lines and measuring lines	

### 8.2 Maintenance Procedure

The maintenance procedure is described in detail step-by-step in our video tutorial and our pictorial descriptions. Instructions for our products can be found in the download area of our website. Should you have any problems, please feel free to contact us directly.

If components have been removed, make sure they are mounted correctly, reinstall all fastening elements and observe the screw tightening torques.

**ATTENTION**



Prior to recommissioning, observe the following:

- Make sure that all maintenance work has been carried out and completed in accordance with the data and information given in these instructions.
- Make sure that no unauthorized persons stay in the danger zone.
- Make sure that all covers and safety devices have been installed and are working properly.

**DANGER**



For recommissioning, please refer to the relevant manufacturer's documentation of the gas pressure regulator installed in the system or chapter 1 and 5.4 as well as the work instructions of the system operator, and the other safety regulations for the system in which the regulator is installed.

To guarantee smooth operation, we recommend always keeping a maintenance set in reserve.

**Note**

### 8.3 Table of Screw Tightening Torques $M_A$

Item no.	S100 / 025 S100 / 040 S100 / 065	S100 / 050 S100 / 080 S100 / 100 S100 / 125	S100 / 150 S100 / 200
53	M8 / 18 Nm	M10 / 36 Nm	M12 / 62 Nm
54	M6 / 8 Nm	M6 / 8 Nm	M8 / 18 Nm
56	M8 / 18 Nm	M10 / 36 Nm	M12 / 62 Nm

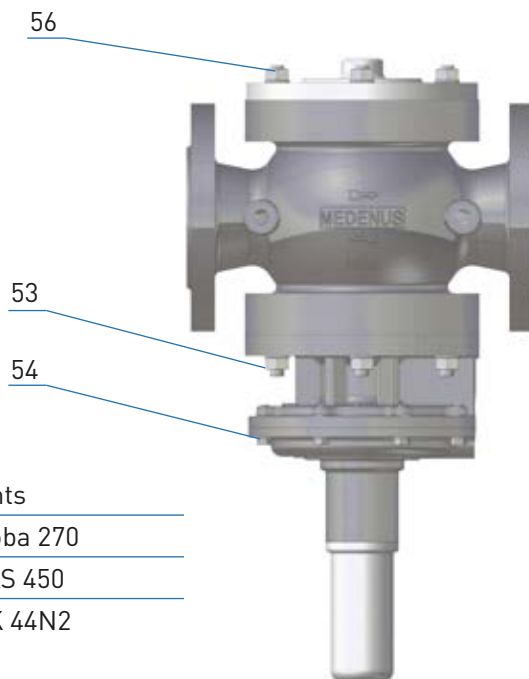

### 8.4 Lubricants Table

Components (apply a thin layer)	Lubricants
All O-rings	Syntheso Proba 270
All fastening and locking screws	Anti Seize AS 450
Balls	Unisilkon TK 44N2

### Oxygen Model

For oxygen models, a suitable grease which is approved for the use with oxygen must be used.

**ATTENTION**



### 8.5 Screw Retention

Components (apply a thin layer)	Adhesive and sealing agent
Stud bolts	Loctite-648

## 9 Replacement and Disposal

After the device has reached the end of its useful life, it must be dismantled and disposed of in an environmentally compatible manner. During dismantling, components that may present a risk of injury by contamination, depending on the medium, are removed. Depending on the processed medium, the components must be properly decontaminated. Diffusible components (diaphragm, O-ring, etc.) may have to be taken to a special disposal unit, depending on the medium used.

**ATTENTION**



If no return or disposal agreement has been signed, dismantled components should be recycled:

- Metals should be scrapped
- The remaining components should be disposed of after sorting according to material.

Alternatively, scrapping by MEDENUS can be agreed with the service. The return is at your own expense, the disposal by MEDENUS is free of charge.

**For technical information, please contact our customer service:**

MEDENUS Gas-Druckregeltechnik GmbH  
Im Langen Feld 3  
D-57462 Olpe

Phone +49 (0) 2761 / 82788-0  
Fax +49 (0) 2761 / 82788-9

E-mail [service@medenus.de](mailto:service@medenus.de)  
Internet [www.medenus.de](http://www.medenus.de)

In addition, we are always interested in information, suggestions and experience resulting from the application and which can be valuable for improving our products.

**Note**

# 10 Troubleshooting

Description of the error	Possible cause	Elimination
No internal tightness in closed position	Actuator dirty or damaged	Check valve seat and valve plate (seal) for damage and dirt
	Pressure compensation ball valve dirty or sealing elements damaged	Check ball valve and replace if required
SSV cannot be opened	No pressure compensation at actuator	Perform pressure compensation via the SSV by pulling at the pull knob *
SSV cannot be engaged	Difference between response pressure and operating pressure or between upper and lower response pressure is too small	Correct response pressure settings consider required re-engagement differential (see product overview S 100)
	Only in case of underpressure switching: Diaphragm in the control device defective or incorrectly installed	Check diaphragm and replace it, if necessary
	Pressure at the measuring point too high or low (only with underpressure switching)	Lower or increase pressure at measuring point to operating value (GPR setpoint value)
	Sluggishness of the trigger mechanism due to dirt / wear	Service switching device and replace if worn-out mechanically
Permissible response pressure group is exceeded Irregularities in response behavior	Difference between response pressure and operating pressure or between upper and lower response pressure is too small	Correct response pressure settings consider required re-engagement differential (see product information on S 104) **
	Diaphragm in the control device incorrectly installed	Check diaphragm for irregular tension
	Sluggishness of the trigger mechanism due to dirt / wear	Service switching device and replace if worn-out mechanically
Gas escapes through breather line	Diaphragm clamping has become loose Diaphragm is damaged or has been mounted incorrectly O-ring sealing (item 7) dirty or damaged	Check diaphragm for fastening, damage, and correct fit Check O-ring and replace it, if necessary

\*) The pull knob must be pulled for the entire duration until pressure compensation is complete. Check whether the shut-off valve downstream of the regulator is closed.

\*\*) Differential pressures between GPR, SSV and system SRV must reflect the response and closing pressure groups as well as the re-engagement differentials of the devices in order to avoid any unintended SRV switching.

**Note**

# 11 Spare Parts

## 11.1 Spare Part Drawing of Safety Shut-Off Valve SSV

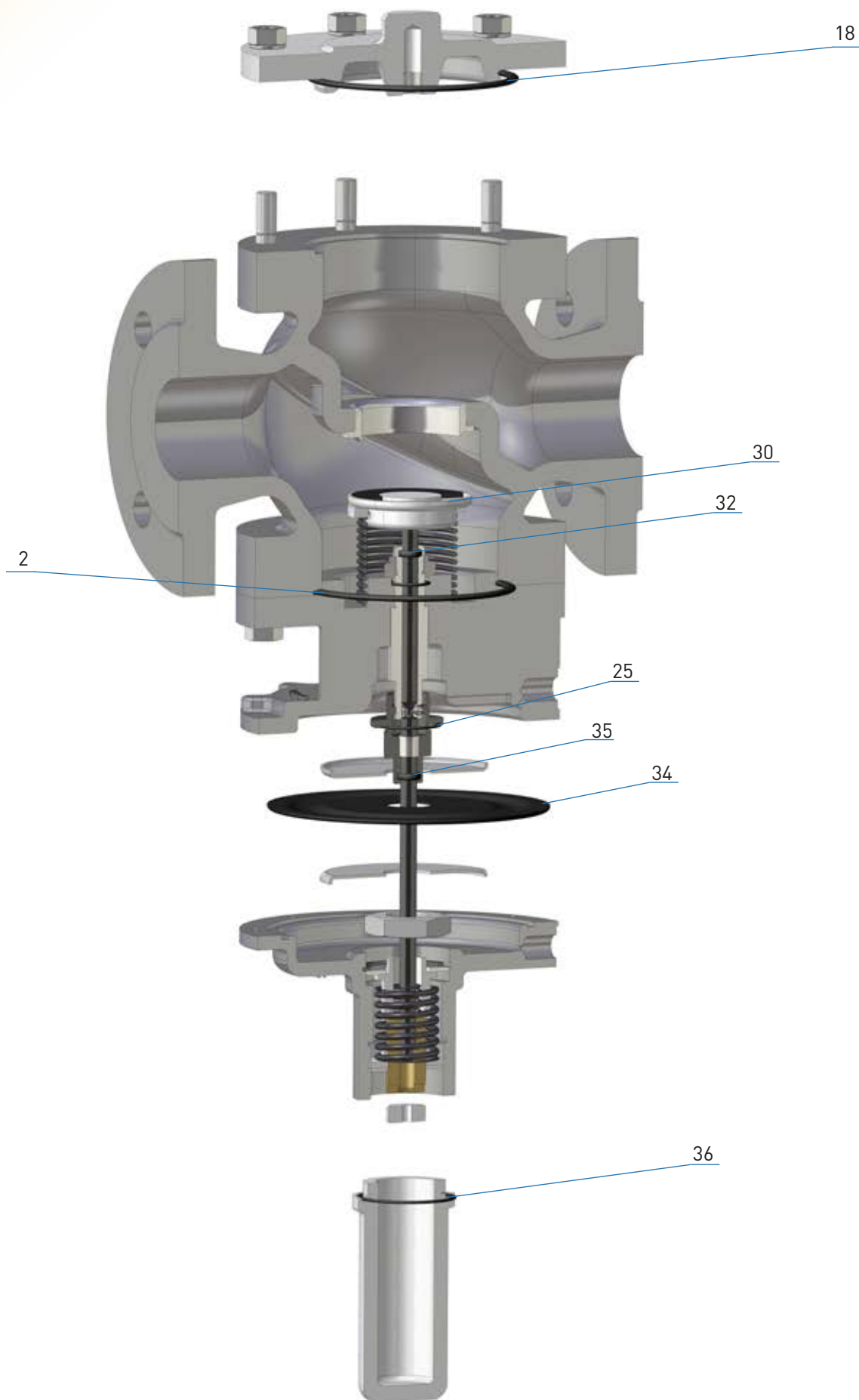

## 11.2 Parts for Maintenance Work

### Valve Plate SSV / Diaphragm SSV

Item no.	Name	Quantity	Exception	S100 / 025 S100 / 040	S100 / 050 S100 / 080 S100 / 100 S100 / 125	S100 / 065	S100 / 150	S100 / 200
30	Valve plate	1		<b>VT-201</b>	<b>VT-206</b>	<b>VT-204</b>	<b>VT-208</b>	<b>VT-210</b>
			DN 050		<b>VT-204</b>			
34	Diaphragm	1		<b>M-201</b>	<b>M-201</b>	<b>M-201</b>	<b>M-202</b>	<b>M-202</b>

### O-Rings and Sealing Rings

Item no.	Name	Quantity pcs.	S100 / 025 S100 / 040	S100 / 050 S100 / 080 S100 / 100 S100 / 125	S100 / 065	S100 / 150	S100 / 200
2	O-ring	1	0-014	0-036	0-018	0-045	0-046
18	O-ring	1	0-014	0-036	0-018	0-045	0-045
25	O-ring	1	0-001	0-001	0-001		
32	O-ring	1	0-007	0-007	0-007	0-009	0-009
35	O-ring	1	0-007	0-007	0-007	0-009	0-009
36	O-ring	1	0-013	0-013	0-013	0-014	0-014
<b>O-ring set order number:</b>			<b>OS-031</b>	<b>OS-032</b>	<b>OS-033</b>	<b>OS-034</b>	<b>OS-035</b>

### Example:

Safety shut-off valve: S100 / 100 / MD-R

Spare parts according to tables in 11.2

Valve plate SSV: **VT-206**

Diaphragm SSV: **M-201**

O-ring and sealing ring set: **OS-032**

**Info:** The allocation of individual parts is done according to the item no. in the tables in 11.2, conforming to the spare parts drawings in 11.1.

## 12 Accessories / Options

### 12.1 AV 530 breather valve

#### 12.1.1 Use

- On SSV control devices
- On regulators (pilots)
- With low-dynamic regulation sections (one full stroke)
- On the SRV

(Option not available for hydrogen version H<sub>2</sub>)

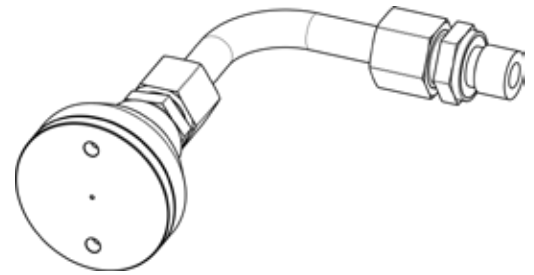

#### 12.1.2 Application / Function

The breather valve is used as replacement for the costly and time-consuming laying of breather lines and for securing the installation room against inadmissible escape of gas from diaphragm comparator compartments of gas pressure regulators and safety shut-off valves.

Safety shut-off valves (SSV) of functional class A are triggered automatically and seal gas-tight.

In compliance with EN 12186:2014, the use of the AV guarantees that in case of a defect of the working diaphragm, escape of gas from the breather connection of the gas pressure regulator or of the safety shut-off valve of more than 30 l/h is prevented.

#### 12.1.3 Technical Data

• <b>Type</b>	AV
• <b>Max. allowable pressure PS</b>	25 bar
• <b>Max. operating pressure p<sub>max</sub></b>	25 bar
• <b>Max. allowable flow rate</b>	30 l/h

- **Connection type** Male thread G 1/4"
- **Temperature range class 2** (operating/ambient temperature) -20 °C to +60 °C

Gas Pressure Regulator

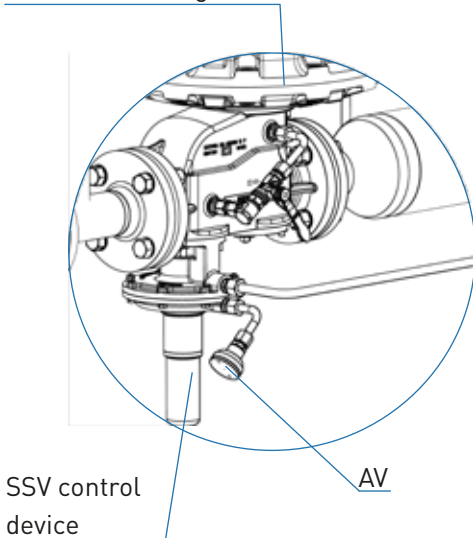

Application example on the SSV

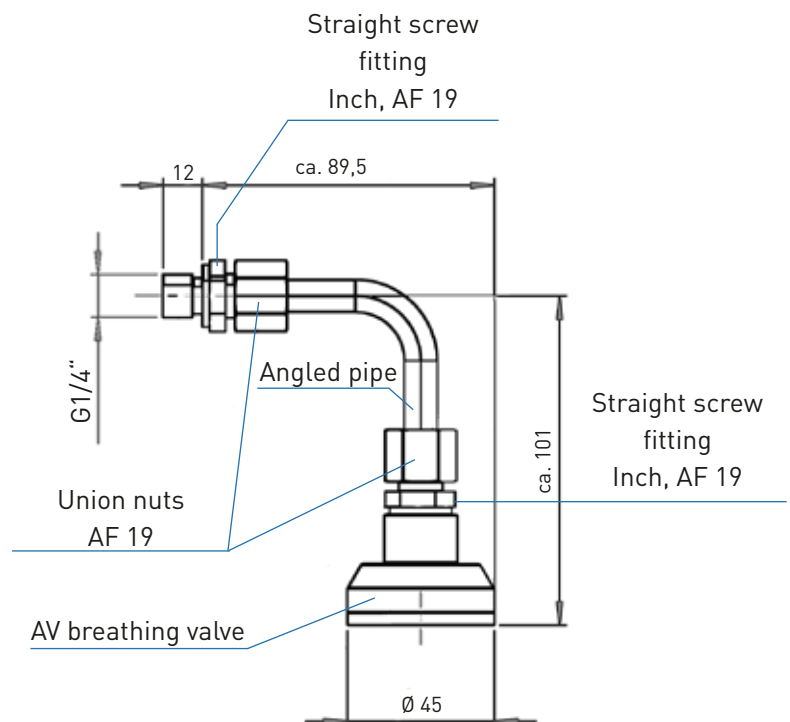

## 12.2 Signal Transmitter / Reed Contact

### 12.2.1 Use

- On SSV-Control Devices

### 12.2.2 Application / Function

The signal transmitter is used in conjunction with Medenus GmbH-products to monitoring the position of the safety shut-off valve (closed or open position) by means of a remote display.

A built-in neodymium magnet in the pull knob of the SSV and a set switching distance to the reed contact allow the position of the SSV to be sensed by the sensor. The signal is transmitted via remote display.

If the SSV switches into the closed position, the switching distance is exceeded and the sensor will lose the signal.

This guarantees continuous monitoring of the SSV control device.





### 12.2.3 Technical Data

<b>Signal transmitter mode</b>	<b>MR500A</b>
• Electrical Design	NAMUR
• Output function	Normally open
• Dimensions (mm)	30,5 x 5 x 6,5
• Weight (g)	91,2
• Ambient temperature (°C)	-25...70
• Protection	IP 65; IP 67
• Mounting	flush mountable
• Cylinder type	T-slot cylinder
• Display switching status	1 x LED, yellow
• Connection to switching amplifiers	yes
• Switching amplifiers	Connection to certified intrinsically safe circuits with the max. values: U=15 V / I=50 mA / P=120 mW
• Nominal voltage DC (V)	8,2
• Current consumption (mA)	Target not detected ≤ 1: Target detected ≥ 2,2
• Protection class	III
• Reverse polarity protection	yes
• Short-circuit protection	no
• Overload protection	no
• Response sensitivity (mT)	2,1
• Travel speed (m/s)	10
• Hysteresis (mm)	1
• Repeatability (mm)	< 0,2

- Max. fall time (ms) 0,1
- Max. switch time incl. bounce 0,6
- Approval BVS 09 ATEX E164; IECEx BVS 09.0065

ATEX marking:

-  II 1G Ex ia IIC T4 Ga
-  II 1D Ex ia IIIC T135°C Da
- EMC:

EN 61000-4-2 ESD	- kV CD / 8 kV AD
EN 61000-4-2 HF radiated	10 V/m
EN 61000-4-4 Burst	2 kV
EN 61000-4-6 HF conducted	10 V
EN 55011 emission	class B

- MTTF (years) 21140
  - Max. internal capacity (nF) 10
  - Max. internal inductance (µH) 400
  - Material housing: PA
  - Material fastening clamp: stainless steel
- Remark: No LED function in case of polarity reversal in DC operation

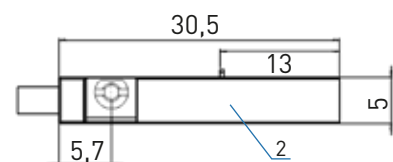
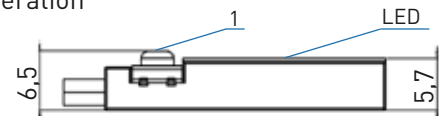

- 1 Fastening clamp with combined slot / Hexagon socket head AF 1,5
- 2 Sensing face

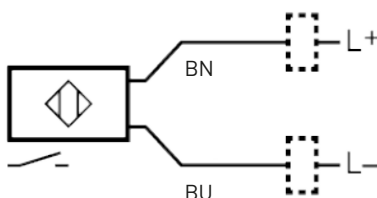

Core colours:  
BN= brown  
BU= blue

## 12.2.4 Mounting

- Replace the pull knob of the SSV spindle with the pull knob with the neodymium magnet
- Slide the signal transmitter into the groove of the SSV cap when SSV is open
- As soon as the operating indicator lights up: STOP! Assembly point has been reached.
- Fix the signal transmitter to the mounting point using a fine screwdriver or Allen key AF 1,5
- Perform a functional test: If the SAV cap is removed, the operating indicator must go out.

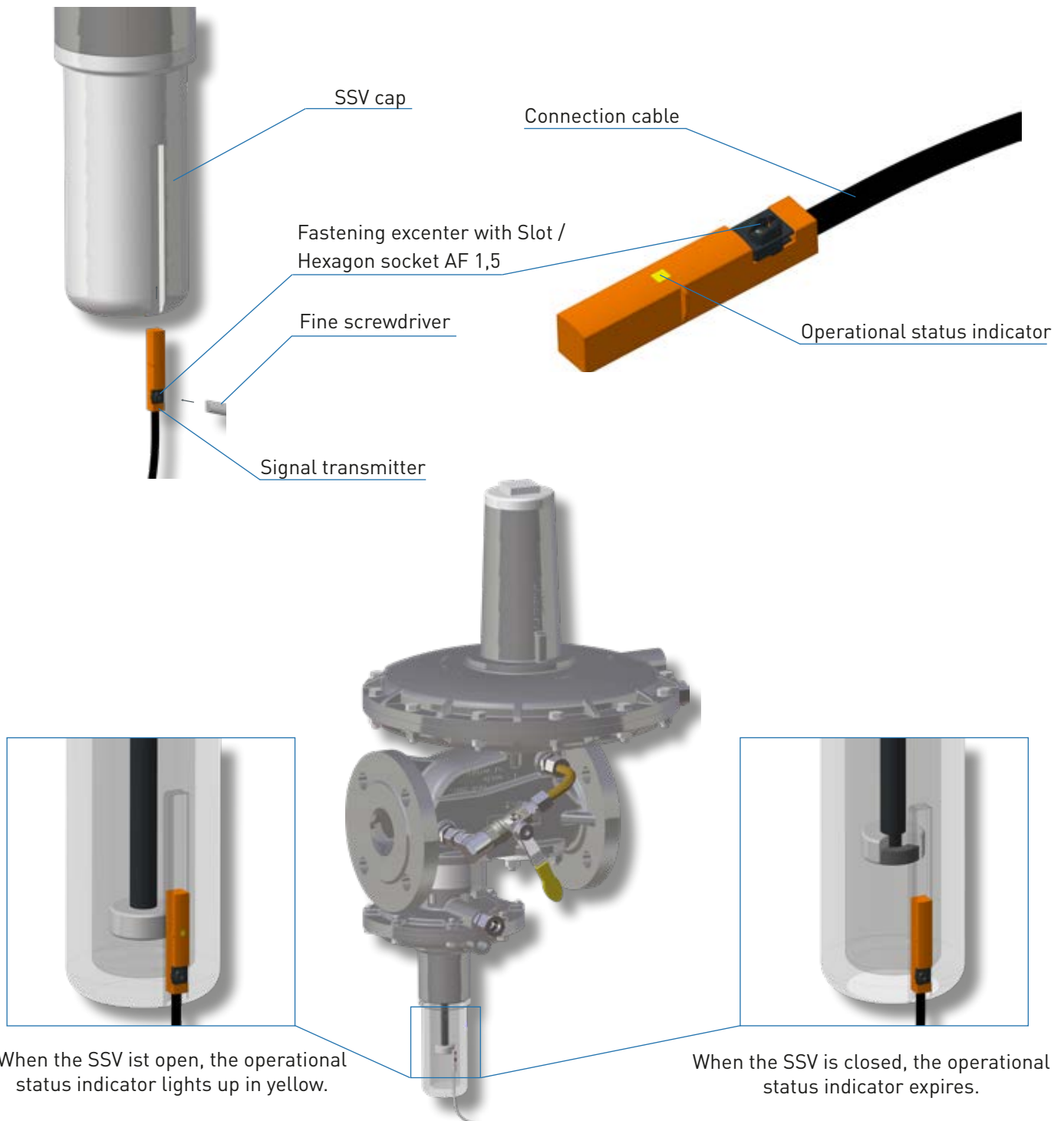

## 12.2.5 Safety instructions

### Must be read prior to using the neodymium magnet!

#### Important safety instructions for general and responsible handling of the neodymium magnet

Please pass on these instructions to all employees, customers and other people who are handling our products or parts derived from them.

Please read these instructions carefully before using the neodymium magnets. For any further questions, please feel free to contact us.

The company "magnets4you GmbH" shall not assume any liability for damage caused by improper handling of the magnets.

#### Hazards caused by magnets



**Risk of injury caused by crushing**

**Risk of injury caused by splinters**

**Hazards caused by magnetic fields**

**Pacemakers, magnetic data carriers (credit cards, memory cards, etc.)**

**Electronic devices (mobile phones, computers, monitors, etc.)**

**Risk of fire**

**Health risks in contact with foods and drinking water**

#### Handling

Do not place any iron-containing parts (tools, nails, knives, etc.) in the vicinity of the magnets.

Magnets can collide or adhere to other metallic surfaces, possibly resulting in splinters or brittleness.

Wear safety goggles and protective gloves – in order to avoid eye injuries and crushing!

Persons wearing pacemakers must not be exposed to magnetic fields.

Electronic devices and magnetic data carriers must be kept away from magnetic fields.

Magnets should not be processed mechanically, sawed or drilled.

The resulting drilling/magnet dust is extremely flammable.

Alternatively, magnets can be glued / sunk for fastening.

Keep the magnets away from open heat and flames!

The magnets are provided with a thin coating (nickel, gold or zinc) that can be removed or changed by excessive use.

It is recommended never to use AlNiCo magnets in direct contact with foods, since metal ions can dissociate in water-containing media.

#### Transport

When shipping magnets, the current regulations for scattered magnetic fields during air transport must be observed (IATA Hazardous Goods Regulations). These regulations also apply to built-in magnets.

Neodymium magnets and end products prepared from them may not be imported directly or indirectly to the following countries: USA, Canada and Japan.

#### Increased caution for children

Keep neodymium magnets out of the reach of children. Children are at risk of playing with the magnets, inserting them into sockets, swallowing them or their fingers getting caught!

Children under the age of 10 should not handle magnets at all.

Source: magnets4you GmbH / Safety instructions Use of neodymium magnets / URL <http://www.magnet-shop.net> / Last update: 11/2013

## 12.3 SSV manual and remote release

### 12.3.1 Use

- On SAV control devices

### 12.3.2 Application / Function

The direct-acting solenoid valve is used as electromagnetic remote release for closing the safety shut-off valve.

Only for SSV control devices of functional class A.

Cannot be used in conjunction with a breathing valve AV530 on SSV!



Upon being energized or in case of power failure, the valve closes the impulse line, resulting in the pressure falling below the response pressure to be monitored. As a result, the SSV actuator shuts off the gas flow gas-tight.

After being released, the safety shut-off valve can only be opened by hand and engaged in the open position.

### 12.3.3 Technical Data

- Housing material stainless steel, polyamide (flange)
- Sealing material FKM (EPDM upon request)
- Media Neutral gases and liquids (e.g. compressed air, city gas, grid gas, water, hydraulic oil, petrol). Suitable for technical grade vacuum.
- Media temperature -10° to +100 °C (PA coil) up to 120 °C epoxy
- Polyamid coil (FKM seal) Coil
- Ambient temperature max. +55 °C
- Viscosity max. 21 mm<sup>2</sup>/s
- Line connection G 1/8, G 1/4, flange (SFB)
- Operating voltage 24 V DC, 24 V/50 Hz, 230 V/50 Hz
- (other voltages upon request)
- Voltage tolerance ±10%
- Nominal operating mode / Single valve Permanent operation 100%
- Electrical connection DIN EN 175301-803 form A for device socket
- Type 2508 (see ordering table accessories)
- ATEX/IECEX version potted with 3 m cable
- Installation position Any, preferably drive pointing upwards
- Degree of protection IP65 with device socket, ATEX/IECEX terminal connection version and cable connection version
- NEMA 4x with device socket 2508 or 2509
- for VA versions (other versions upon request)
- Thermal insulation class coil Polyamide class B (epoxy class H upon request)
- Coil material polyamide (epoxy upon request)
- Nominal width DN 1.5 - 2.5

Further technical data and information on the 3/2-way valve, such as information on ATEX, are available for download on the manufacturer's homepage.

**Note**

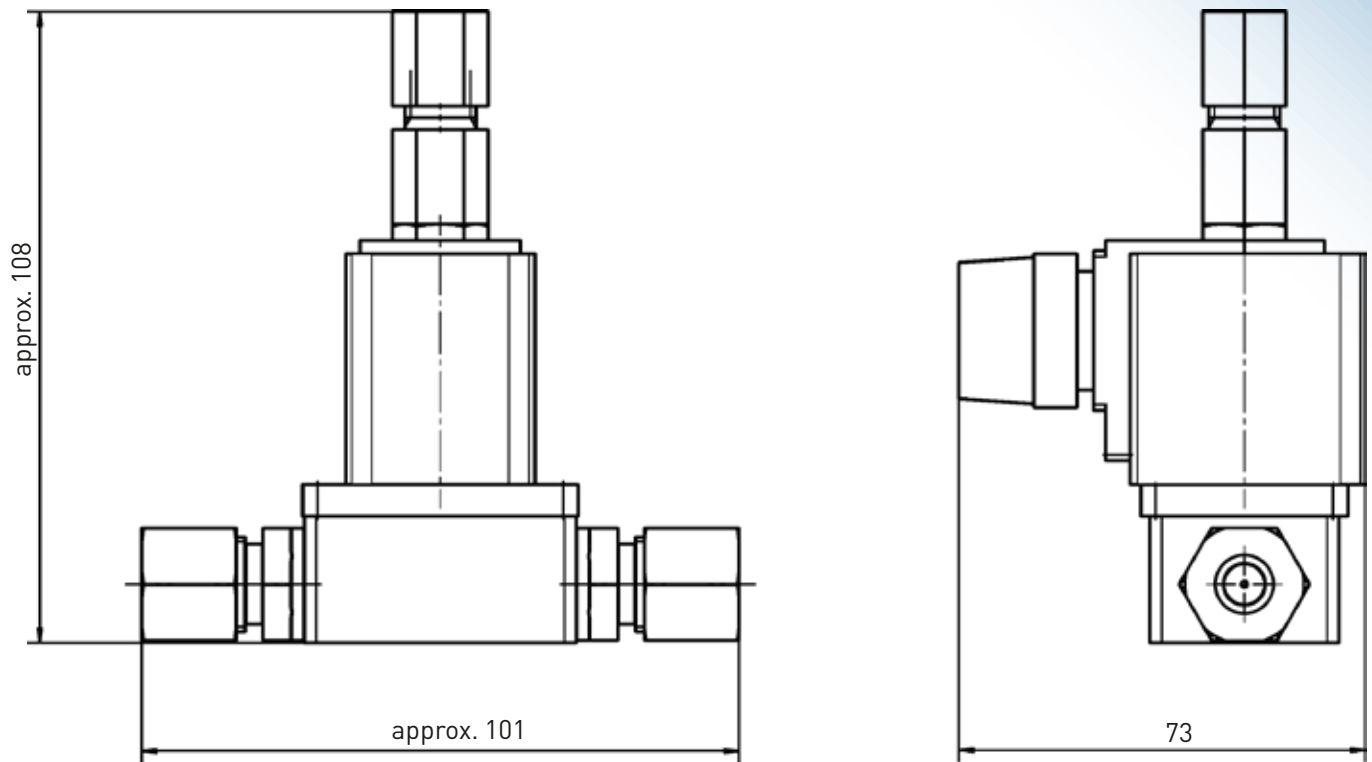

### 12.3.4 Application example

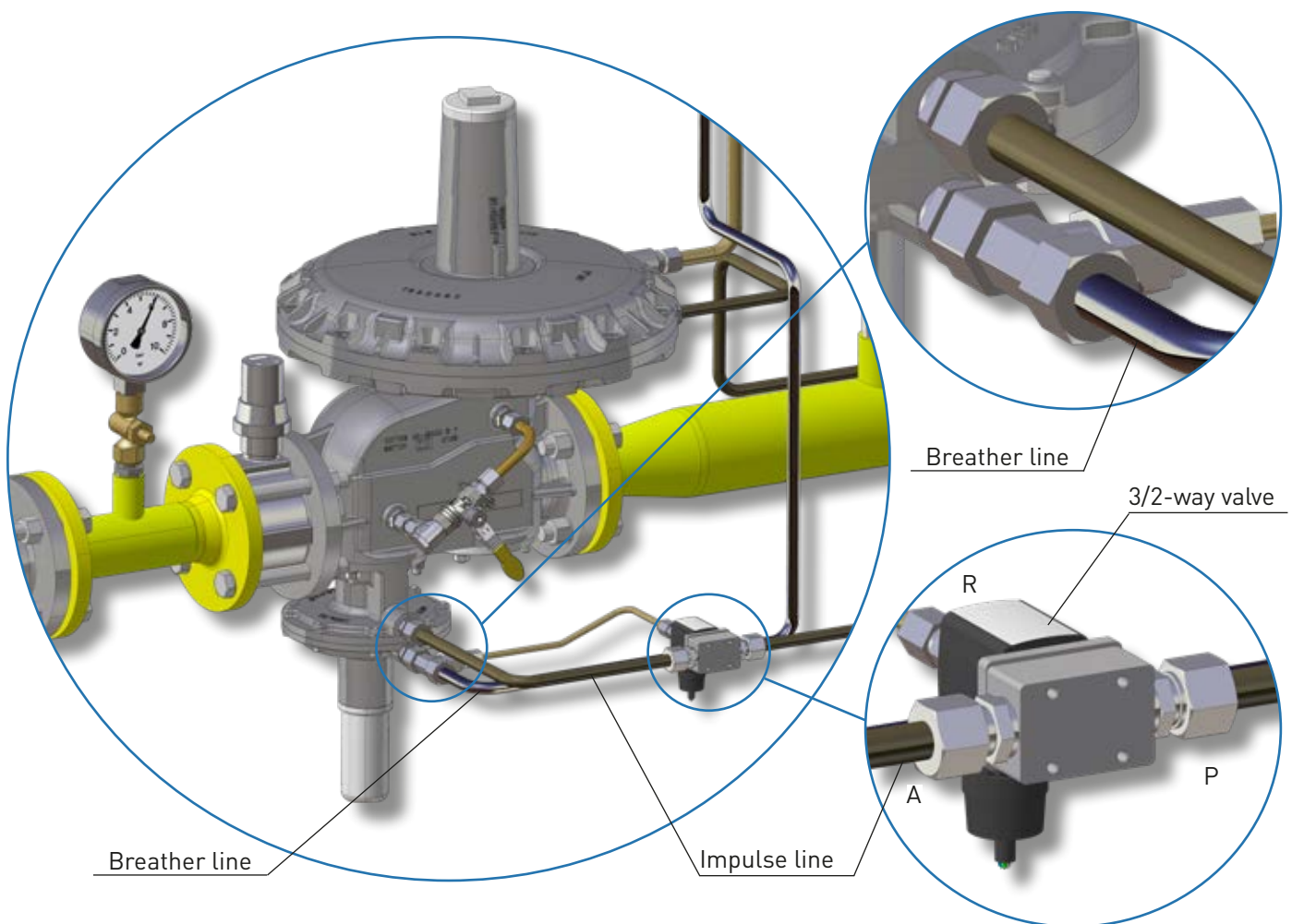

## 13 Tools

### 13.1 SSV tightening tool

The tightening tool made of stainless steel is used for replacing the SSV diaphragm in your MEDENUS safety shut-off valve.

Old design

- Width across flats 22
- Stainless steel 42CrMo4

New design

- Width across flats 32
- EN AW-2007 or similar



Old design



New design

# Declaration of Conformity

---

Manufacturer: Medenus Gas-Druckregeltechnik GmbH

Address: Im Langen Feld 3  
D-57462 Olpe

---

declares under sole responsibility that the product:

**S 100** Safety shut-off valve (SSV) for upper and lower shut-off pressure

have been subjected to an EC-type examination and conform to the basic requirements of the directives GAR (EU) 2016/426 EC-Gas Appliances Regulation and 2014/68/EU A III B EC-Pressure Equipment Directive in the respective current version.

---

Marking (PIN) according to Pressure Equipment Directive and Gas Appliances Regulation

**CE-0085AQ0880 model S 100**

---

Notified body (EU type examination: Module B)

DVGW CERT GmbH  
Josef Wirmer Straße 1-3  
D-53123 Bonn, Germany  
Notified Body number: 0085

The basis of the EC type examination are the harmonized European standards and / or national standards, as well as the European directives and / or regulations:

2014/68/EU A III B EC Pressure Equipment Directive	(15.04.2014)
GAR (EU) 2016/426 A III B EC Gas Appliances Regulation	(09.03.2016)
DIN EN 14382	(01.11.2019)

---

Monitoring of the EC quality assurance system (module D)

DVGW CERT GmbH  
Notified Body number: 0085

Registration No. Pressure Equipment Directive **SD-0085BQ0510**

Registration No. Gas Appliances Regulation **SE-0085BQ0510**

---

Olpe,  
07.08.2023



Alexander Christiani  
Managing Director

In the download area of our homepage, this document is available in different languages. You can use the following QR codes and links to go directly to this document in your language.



**German:**

[http://medenus.de/files/upload/downloads/S100/BWA\\_S100\\_de.pdf](http://medenus.de/files/upload/downloads/S100/BWA_S100_de.pdf)



**MEDENUS** Gas-Druckregeltechnik GmbH

Phone +49 (0)2761 82788-0

Fax +49 (0)2761 82788-9

Im Langen Feld 3 / D-57462 Olpe

[info@medenus.de](mailto:info@medenus.de)

[www.medenus.de](http://www.medenus.de)

**EN**