

MEDENUS

Gas Pressure Regulation



Gas Pressure Regulator R 50

Product Information

EN

Table of Contents

Application, Features , Technical Data	4
Application	4
Features	4
Type of model (options)	4
Technical Data	4
Design and function	5
K_G^* value and diaphragm assemblies	6
Diaphragm assembly setpoint spring table	6
Dimensions, connection and weight	7
Dimensions and weight	7
Dimensional drawing	7
Connection of test leads and breathing lines	7
Ordering data	9
Contact	10
Notes	12-14

List of abbreviations and formula symbols

AC	accuracy class	PS	maximum allowable	SG	closing pressure class
HPS	high-pressure screw spindle		pressure	t_u	inlet gas temperature
K_G	values	p_u	inlet pressure	VS	valve seat
p_d	outlet pressure	Q_n	standard volumetric flow rate	w_d	outlet gas velocity
p_{ds}	setpoint of outlet pressure	DA	diaphragm assembly	w_u	inlet gas velocity
		BV	breather valve	ρ_n	gas density

*) K_G value for natural gas

Application, Features , Technical Data

Application

Gas pressure regulator (GPR) direct-acting, (working without power supply), for installations according to DVGW - Code of Practice G 491 (A) and G 600 (A) (TRGI)

Particularly suitable for dynamic regulating lines (e.g. gas firing installations, burner circuits, gas-powered operation)

For use as equipment part for gas consumption installations according to EC Directive (90/396/EEC)

For use for gases according to DVGW - Code of Practice G 260 / G 262 and neutral non-aggressive gases.

(other gases on request)

Features

- Integral flameproof design (IS)
- diaphragm assembly with internal or external measuring line

Type of model (options)

- Oxygen model

Technical Data

Type	R 50
Model	Integral Pressure resistant (IS)
Maximum allowable pressure PS	3 bar
Max. gas inlet pressure $p_{u,max}$	3bar
Nominal width	DN 25
Nominal size	Rp 1" (DN 25), Rp 1½" (DN 40), Rp 2" (DN 50) (NPT thread on request)
Type of connection	Internal thread acc. to EN 10226-1
Material	
Housing / actuator housing	Al cast alloy*
Temperature range class 2 (Operating / ambient temperature)	-20 °C bis +60 °C
Function, strength and density	DIN EN 334
CE mark according to PED/ PIN number	CE-0085-CR0137
Ex protection	The mechanical components of the device do not contain any potential ignition sources of their own; thus, they do not fall under the scope of ATEX 95 (94/9/EC). The electrical components of the device comply with ATEX requirements.

- *) Corrosivity category according to DIN EN ISO 12944-2.
The categories C1 to C5-I including guaranteed without additional coatings.
For the category C5-M a coating with epoxy resin is recommended.



Application, Features , Technical Data

Design and function

The spring-loaded gas pressure regulator R 50 has the function of keeping the outlet pressure of a gaseous medium constant within allowable limit values, independently of the effect of interferences, such as changes in the inlet pressure and/or in the gas tap, in the connected regulating line on the outlet side. The gas pressure regulator is composed of the actuator housing and the „diaphragm assembly plus actuator“ functional unit.

The valve seat model is pre-pressure-compensated.

The gas flows through the actuator housing in the direction of the arrow. The internal or external measuring line connection is used to pass the outlet pressure to be regulated to the bottom of the diaphragm comparator of the diaphragm assembly. It compares the actual value with the command variable preset by the force of the setpoint spring. The setpoint required in each case is set via the setting screw. Any deviation from the setpoint is transmitted by the valve stem to the actuator, which is adjusted such that the actual value is adjusted to the setpoint.

In case of zero tap, the actuator will close tight, causing the closing pressure to be established.

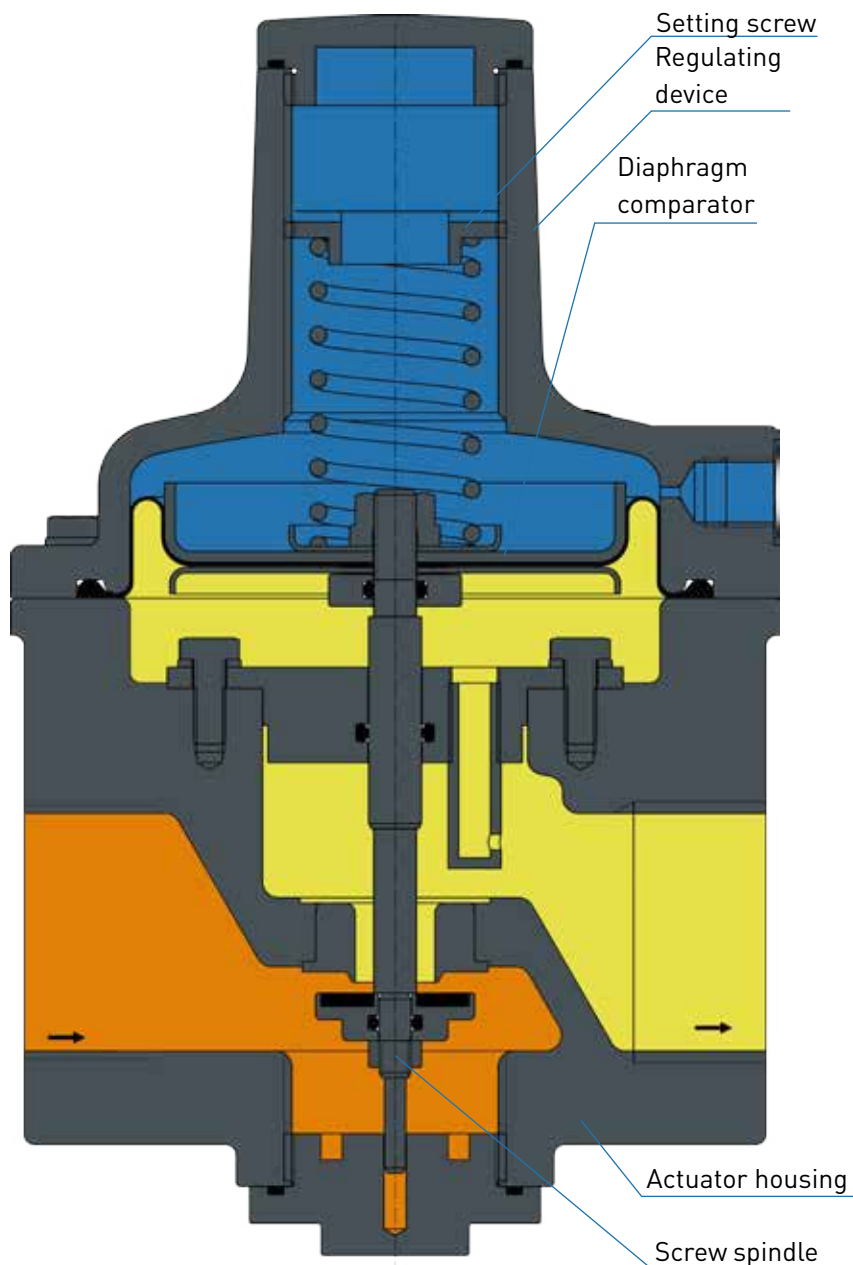

Application, Features , Technical Data

Valve seat diameter, measuring unit diameter

Nominal width	Connection	Ø Valve seat (mm)	maximum flow (Nm ³ /h)	Flow rate coefficient K _G * [(m ³ /(h*bar))]	Ø RE (mm)
DN 25	Rp 1	11,0 / 15,0 / 20,0	100	70/120/200	145
DN 40	Rp 1½	15,0 / 25,0	300	120/380	145
DN 50	Rp 2	15,0 / 25,0	300	120/380	145

Diaphragm assembly setpoint spring table

Note

The setpoint spring ranges for the R 50 gas pressure regulator are pre-pressure dependent. For more detailed information, please contact the MEDENUS Gas Pressure Regulation. The contact data can be found on page 10.

*) with high-pressure spring plate (HD1)

**) with high-pressure screw spindle (HD2)

Dimensions, connection and weight

Dimensions and weight

Nominal width DN	Connection	Ø RE (mm)	A (mm)	B (mm)	L (mm)	HD2 (mm)	X (mm)	Weight (kg)	Weight HD2 (kg)
25	Rp 1	145	173	53	100	112	180	2,5	0,4
40	Rp 1½	145	173	61	140	112	180	3,5	0,4
50	Rp 2	145	173	61	160	112	180	3,5	0,4

Abmaßzeichnung

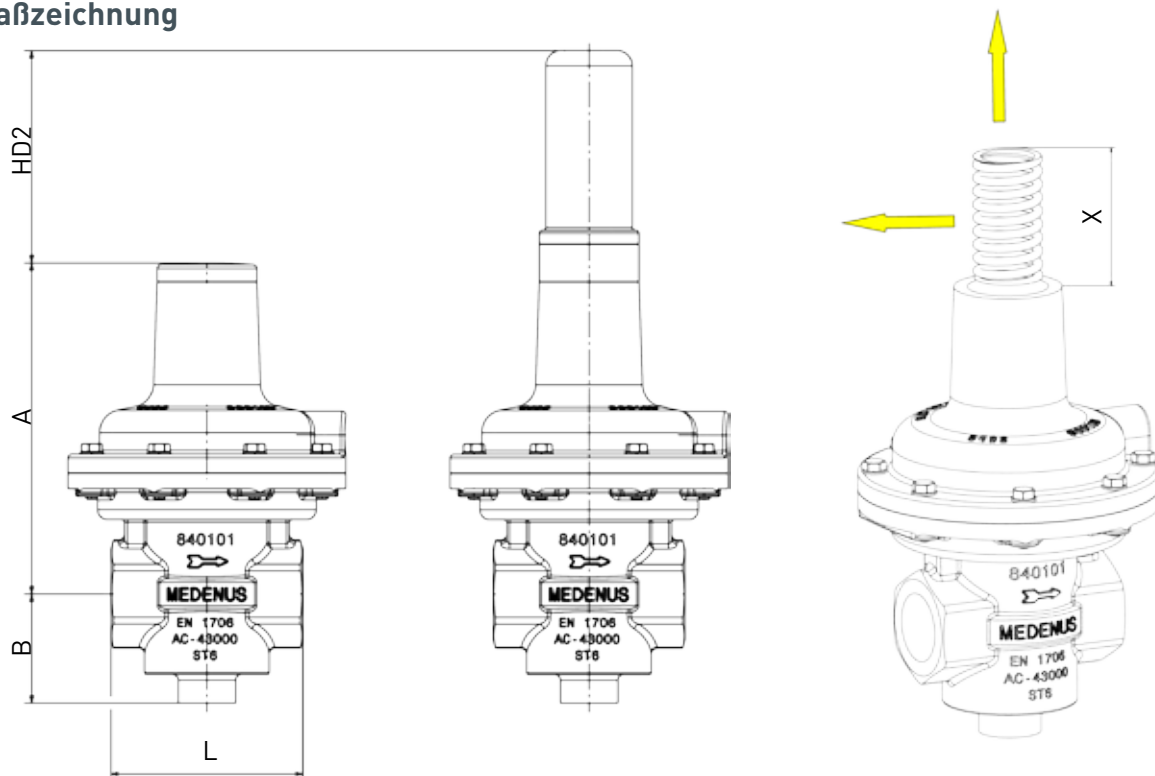

Example:

R50/Rp 1" with HD2

Weight (Regulator + HD2): 2,5kg + 0,4kg = 2,9kg

Dimensions (A + HD2): 173mm + 112mm = 285mm

Note

For installation, start-up and maintenance, the following documents must be observed:

DVGW - Code of Practice G 491 and G 600

Operating and Maintenance Instructions R 50

The gas pressure regulators R 50 shall be installed in the pipeline preferably in horizontal position with vertical position of the diaphragm assembly spring cap. For all nominal widths, the direction of flow is indicated by an arrow on the housing.

*) Pipe connections according to DIN EN ISO 8434-1 (DIN 2353)

Design

Calculation of the required K_G value

The standard flow value for a completely open actuator ($p_u = 2 \text{ bar}$; $p_d = 1 \text{ bar}$) corresponds to the K_G value.

The K_G value refers to natural gas of density 0.83 kg/m^3 at 15°C . For other gases, a flow rate equivalent to that of natural gas is to be expected.

$$Q_{n \text{ natural gas}} = Q_{n \text{ gas}} / \sqrt{(0.83 / \rho_{n \text{ gas}})}$$

$$p_d / p_u > 0,5$$

K_G value at a subcritical pressure ratio

$$K_G = Q_n / \sqrt{p_d \cdot (p_u - p_d)}$$

$$p_d / p_u \leq 0,5$$

K_G value at a supercritical pressure ratio

$$K_G = 2 \cdot Q_n / p_u$$

Note: all calculated pressures are absolute pressures.

Device selection

The device is selected on the basis of its K_G value from the table of flow rate coefficients (page 6)

Note: For spring-loaded devices, a capacity reserve of 10-20 % is recommended in order to comply with the accuracies given.

Checking the gas velocities

$$w = 380 \cdot Q_n / (DN^2 \cdot p_{abs})$$

Note: The factor 380 refers to an operating or gas temperature from approx. 15°C to 20°C . For other temperatures, the velocity must be corrected as follows: $w_{korr} = w \cdot (t_{gas} + 273.15) / 290$

Recommended max. gas velocity at the inlet flange :
 50 - 70 m/s Lower value for deflections upstream of the regulating valve,
 20 m/s for filters connected upstream

Recommended max. gas velocity at the outlet flange:
 100 - 200 m/s Lower value for reducing sound emission

Recommended max. gas velocity at the impulse tap: 15 - 25 m/s Lower value for outlet pressures below 100 mbar

Example:

$$\begin{array}{l} p_{u \text{ min}} \ 5,0 \text{ bar} \quad / \quad p_{u \text{ max}} \ 8,0 \text{ bar} \\ p_{d \text{ min}} \ 0,2 \text{ bar} \quad / \quad p_{d \text{ max}} \ 0,5 \text{ bar} \\ Q_{n \text{ min}} \ 150 \text{ m}^3/\text{h} \quad / \quad Q_{n \text{ max}} \ 200 \text{ m}^3/\text{h} \end{array}$$

$$1,5 \text{ bar} / 6 \text{ bar} = 0,25 < 0,5$$

→ supercritical pressure ratio

$$K_G = 2 \cdot 200 / 6 = 67 \text{ (m}^3/\text{h)/bar}$$

R 51 DN 25 VS 16,5
 K_G - value: 175 (m³/h)/bar

Inlet and outlet nominal width of the pipeline according to the selected device: 25 mm
 Selected widening of the outlet pipeline: 50 mm

$$w_u = 380 \cdot 200 / (25^2 \cdot 6) = 20 \text{ m/s}$$

$$w_d = 380 \cdot 200 / (25^2 \cdot 1,5) = 81 \text{ m/s}$$

$$w_{\text{Impuls}} = 380 \cdot 200 / (50^2 \cdot 1,5) = 20 \text{ m/s}$$

The device selected in the example of nominal width DN 25 can be operated under these conditions.

Note:

For a more detailed interpretation of our gas pressure control devices, the configurator is available on our homepage medenus.de. (Medenus.de/en/service/konfigurator.html)

Ordering data

Example:

Gas pressure regulator: R50/Rp1"/160/11/HDS/BV/WAZ/So

Order selection	Bestellschlüssel:	R51	Rp1"	160	11,0	HDS	WAZ	So
Type	Designation							
R50	R50	R50						
DN - Nominal size	Tabelle S.9		Rp1"					
RE - Control unit	160			160				
D - Orifice (valve seat diameter)	Tabelle S.9				11,0			
High-pressure screw spindle								
without	-							
with high-pressure screw spindle	HDS					HDS		
Acceptance test certificate to EN 10204/3.1								
without	-							
with acceptance test certificate	WAZ						WAZ	
Special model	So*							So

In each selection group, only one option can be selected in each case.

DN - Nominal size

Regulator type	Rp 1"	Rp 1½"	Rp 2"
R50	X	X	X

D - Düse (Ventilsitzdurchmesser)

Regulator type	Nominal size	11,0	15,0	20,0	25,0
R50	Rp 1"	X	X	X	
	Rp 1½"		X		X
	Rp 2"		X		X

So*) for example:

- Oxygen model
- with Breather valve BV

Contact

If you want to know more about our products and services, please contact your local representative or visit our website at www.medenus.de/en.



Managing Director Alexander Christiani

Telephone: +49 (0) 2761 / 82788-18
Fax: +49 (0) 2761 / 82788-9
E-Mail: a.christiani@medenus.de



Field Sales Germany

Jörg Pflugner

Mobile: +49 (0) 170 635 5309
Fax: +49 (0) 2761 / 82788-9
E-Mail: j.pflugner@medenus.de



Head of Sales & Marketing Franz Feichtner

Telephone: +43 (0) 7227 / 211-17
Fax: +49 (0) 2761 / 82788-9
Mobile: +49 (0) 151 / 51002711
E-Mail: f.feichtner@medenus.de



In-House Sales

Maïke Rath

Telephone: +49 (0) 2761 / 82788-11
Fax: +49 (0) 2761 / 82788-9
E-Mail: m.rath@medenus.de



In-House Sales

Jan Arens

Telephone: +49 (0) 2761 / 82788-20
Fax: +49 (0) 2761 / 82788-9
E-Mail: j.arenst@medenus.de



In-House Sales

Stefanie Müller

Telephone: +49 (0) 2761 / 82788-13
Fax: +49 (0) 2761 / 82788-9
E-Mail: s.mueller@medenus.de

Worldwide Sales Agencies:

medenus.de/en/kontakt.html



MEDENUS

Gas-Druckregeltechnik GmbH

Im Langen Feld 3
D-57462 Olpe

Fon: +49 (0)2761 82788-0

Fax: +49 (0)2761 82788-9

E-Mail: info@medenus.de

Internet: www.medenus.de



THE MEDENUS PLUS

10 reasons for good business relations

1. Consultancy expertise and quality standards developed over decades
2. Broad and proven standard range of feedback controllers
3. Modern, fast and efficient production for series products and for individual orders
4. Customized design of pressure regulators and vacuum regulators and special designs
5. Guaranteed deadline compliance with a delivery time guarantee
6. Fast response time in all matters
7. Sufficiently large parts storage for production and spare parts
8. Customized theory & practice training courses
9. Modular design right across the entire product range to facilitate optimized handling of spare parts
10. 100% Made in Germany

Notes

A series of 28 horizontal dotted lines for taking notes.

Notes

A series of horizontal dotted lines for writing notes.

Notes

A series of horizontal dotted lines providing space for handwritten notes.

In the download area of our homepage, different languages of this document are available.
You can use the following QR codes and links to go directly to this document in your language.



Deutsch:

http://medenus.de/files/upload/downloads/R51/Pi_R51_de.pdf



English:

http://medenus.de/files/upload/downloads/R51/Pi_R51_en.pdf



MEDENUS Gas-Druckregeltechnik GmbH

Fon +49 (0)2761 82788-0

Fax +49 (0)2761 82788-9

Im Langen Feld 3 / D-57462 Olpe

info@medenus.de

<http://medenus.de/en/>

EN