

R 101

Construction and function of the R 101

The R 101 is a gas pressure regulator, which ensures the constant outlet pressure given a varying inlet pressure or flow capacity.

The gas flows through the regulator housing in arrow direction. The main diaphragm is actuated via an impulse line from the outlet side by pressure. The required outlet pressure is adjusted at the spring. The valve remains open as long as the outlet pressure is below the seat value. When reaching the set point the regulator valve closes.

The measure work is directly mounted and operates independent from the inlet pressure.

R 101 with single seat valve

Nominal diameters: DN 25, 40, 50, 65, 100



Wheel in use materials

Housing:	Silumin casting	DN 25 - 100
Diaphragm cap:	Silumin casting	
Internal parts:	stainless	
Diaphragms:	50 NBR	
valve discs:	50 NBR, vulcanized	

Connections

Flange PN 16 DIN 2533

R 101 in a gas train

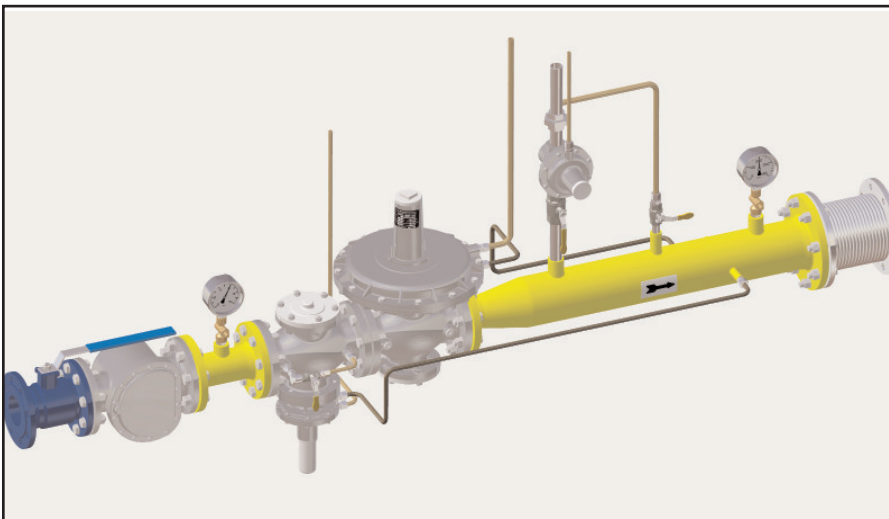

Install space -spring - X

R 101 DN 25-65	210mm
R 101 DN 100	410mm

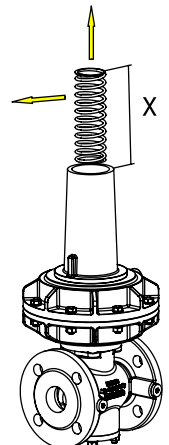

R 101

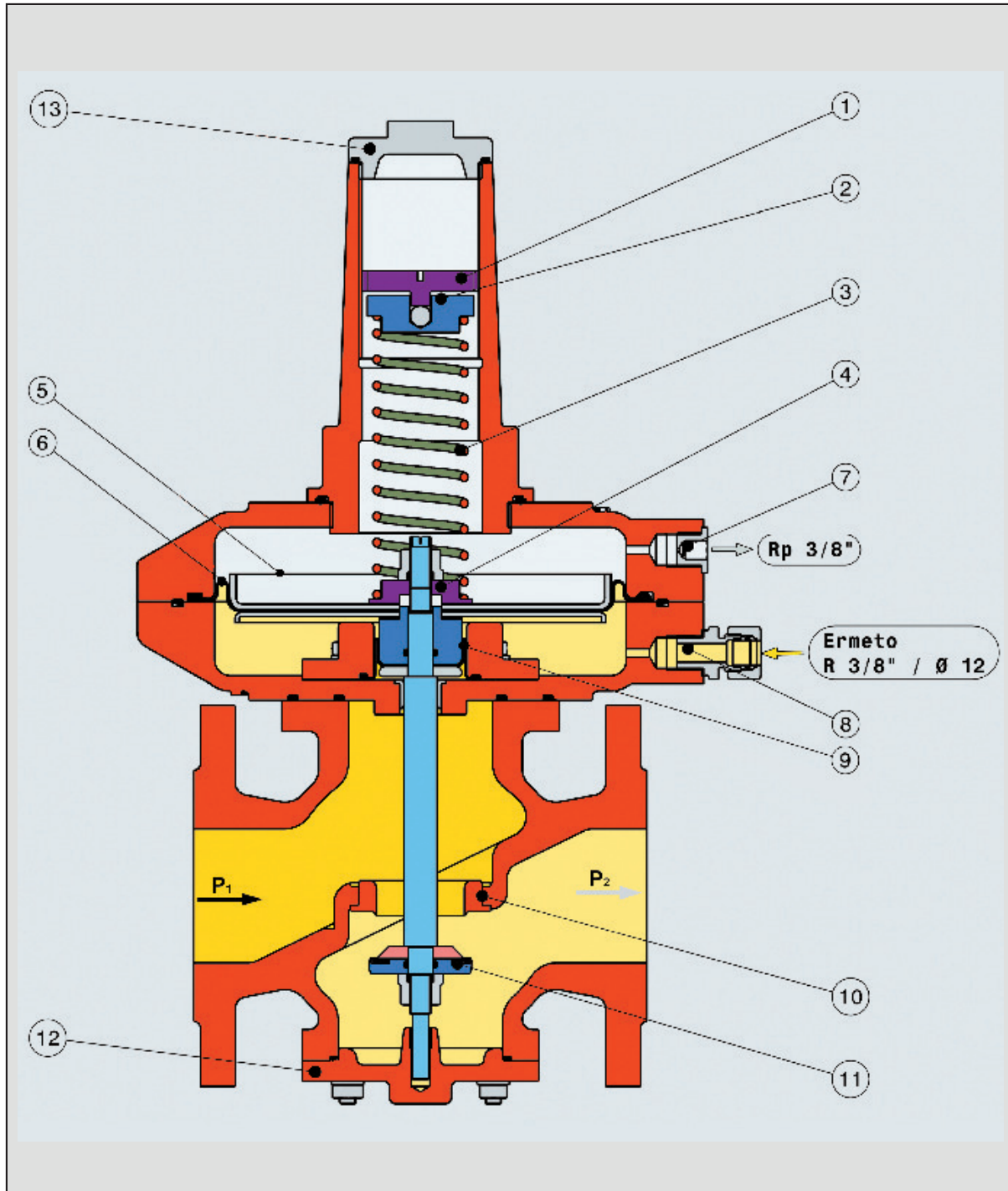

- 1 Pressure setting screw
- 2 Spring disc
- 3 Setting spring
- 4 Feet disc
- 5 Diaphragm disc
- 6 Main diaphragm

- 7 Vent connection
- 8 Impulse connection
- 9 Compensation diaphragm
- 10 Regulator valve seat
- 11 Valve disc
- 12 Cover plate

R 101

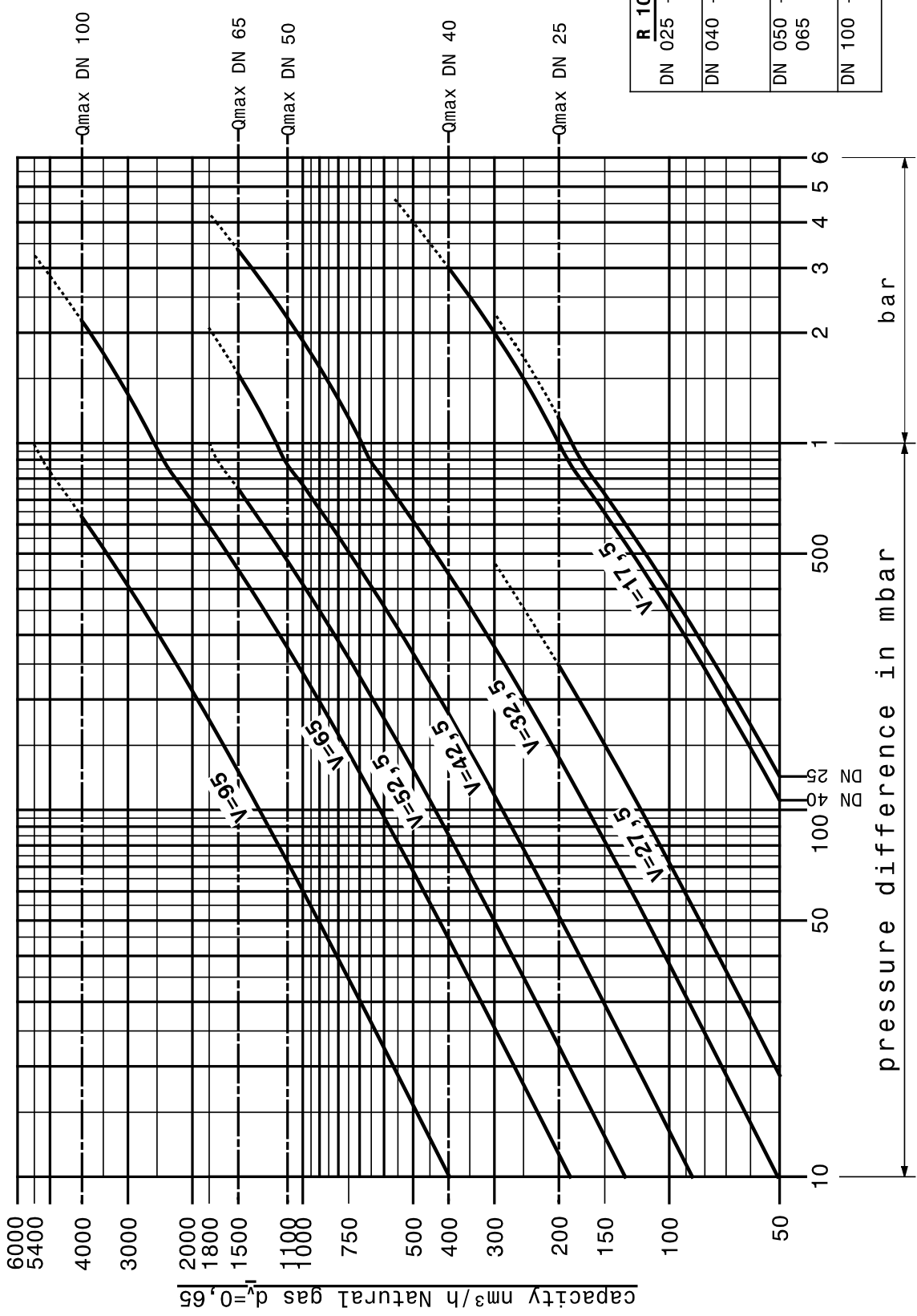

R 101	
DN 025 - 17,5	27,5
DN 040 - 17,5	27,5
DN 050 - 32,5	32,5
DN 065 - 42,5	42,5
DN 100 - 65	65
DN 100 - 95	95

R 101 DN 25

$P_e = P_u$ max. 8 bar
 $P_a = P_d$ 8-1.200mbar
 Q max. 200 Nm³/h
 (300) Nm³/h

KG-Werte

$V_{17,5}$ 186 Nm³/h
 $V_{27,5}$ 459 Nm³/h

Gas characteristics:

suitable for gas of the gas families 1, 2, 3 and other neutral gaseous media.

Ambient-temperature -20...+60°C

Fitting position any

Flow speed 30m/s
(limit 60m/s)

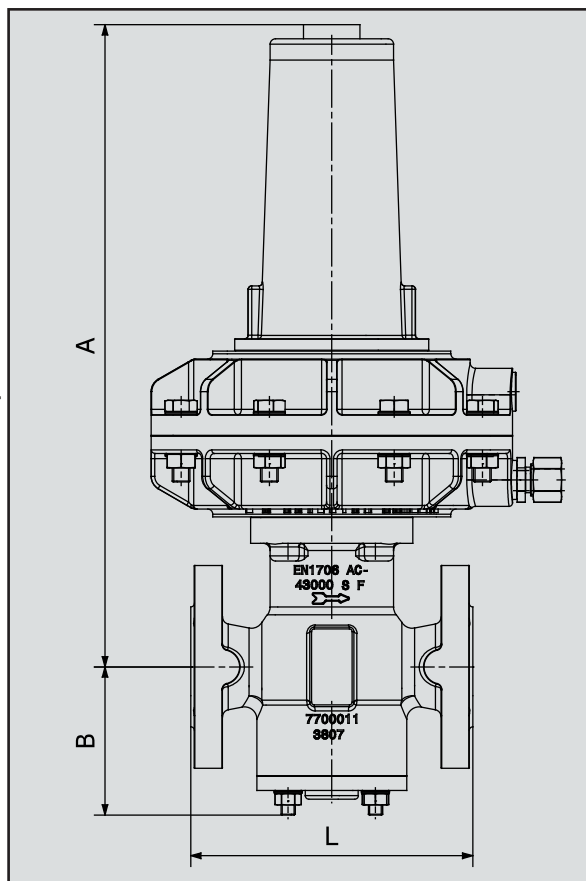

Special design:
high pressure shaft

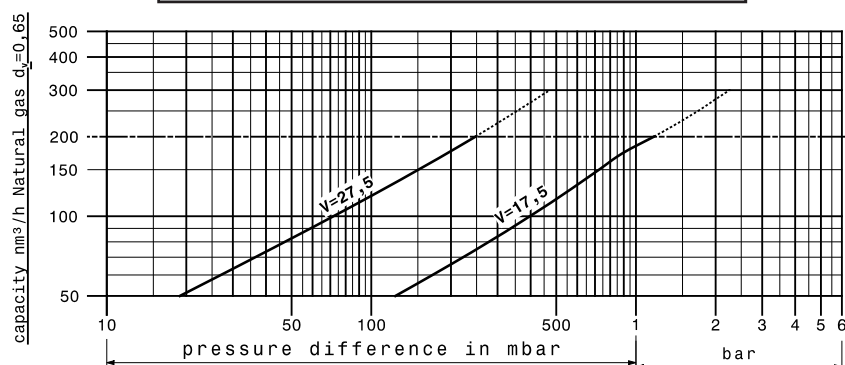

$P_d < 200$ mbar*	$P_d < 750$ mbar*	$P_d < 1.200$ mbar*
10,5kg PN16	8kg PN16	6,5kg PN16
A=346mm B= 84mm L=160mm	A=364mm B= 84mm L=160mm	A=356mm B= 84mm L=160mm
Ø318	Ø205	Ø162

*for higher pressure high pressure shaft

R 101 DN 40

$P_e = P_u$ max. 4 bar
 $P_a = P_d$ 8-1.200mbar
 Q max. 400 Nm³/h
 (600) Nm³/h

KG-Values

$V_{17,5}$ 186 Nm³/h
 $V_{27,5}$ 459 Nm³/h
 $V_{32,5}$ 697 Nm³/h

Gas characteristics:

suitable for gas of the gas families 1, 2, 3 and other neutral gaseous media.

Ambient-temperature -20...+60°C

Fitting position any

Flow speed 30m/s
 (limit 60m/s)

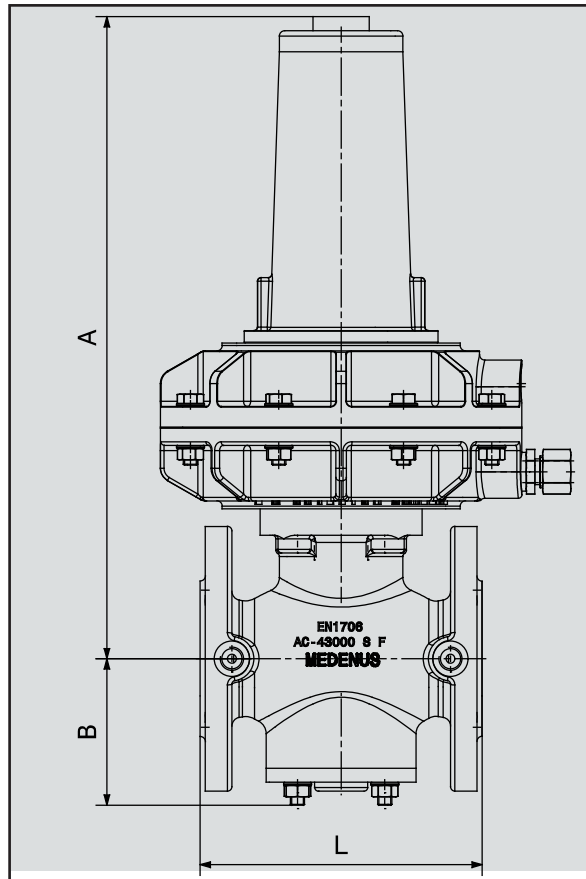

Special design:
high pressure shaft

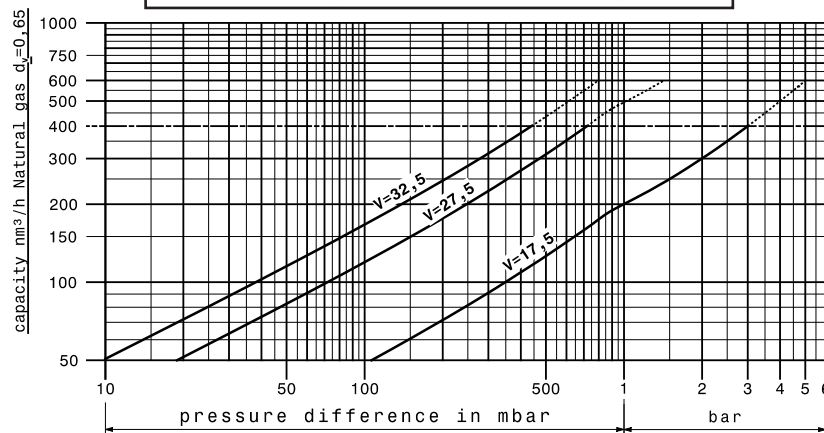

$P_d < 200$ mbar*

11kg
PN16

A=346mm
B= 84mm
L=160mm

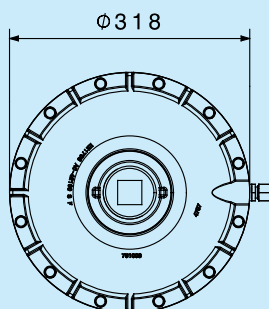

$P_d < 750$ mbar*

9kg
PN16

A=364mm
B= 84mm
L=160mm

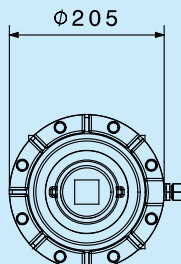

$P_d < 1.200$ mbar*

7,5kg
PN16

A=356mm
B= 84mm
L=160mm

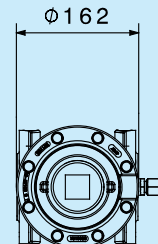

*for higher pressure high pressure shaft

R 101 DN 50

$P_e = P_u$ max. 4 bar
 $P_a = P_d$ 8-1.200mbar
 Q max. 1.100 Nm³/h
 (1.500) Nm³/h

KG-Values

$V_{32,5}$ 697 Nm³/h
 $V_{42,5}$ 1.191 Nm³/h
 $V_{52,5}$ 1.818 Nm³/h

Gas characteristics:

suitable for gas of the gas families 1, 2, 3 and other neutral gaseous media.

Ambient-temperature -20...+60°C

Fitting position any

Flow speed 30m/s
 (limit 60m/s)

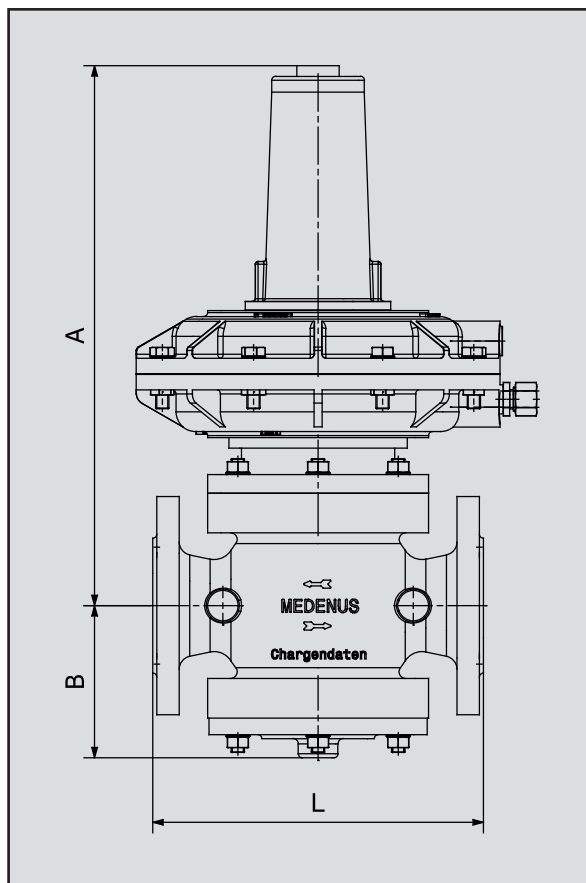

Special design:
 high pressure shaft

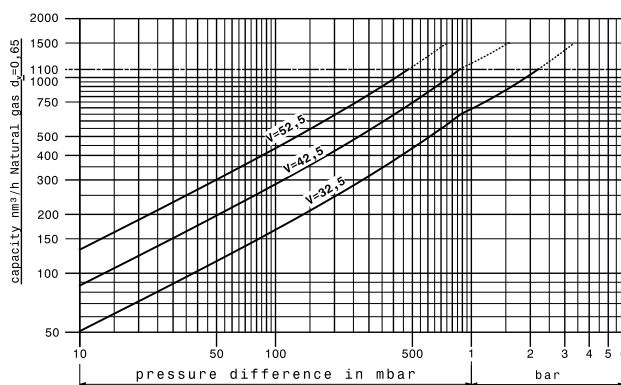

$P_d < 100$ mbar*

22kg
PN16

A=408mm
B=115mm
L=250mm

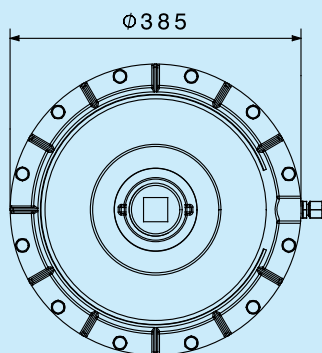

$P_d < 400$ mbar*

18kg
PN16

A=408mm
B=115mm
L=250mm

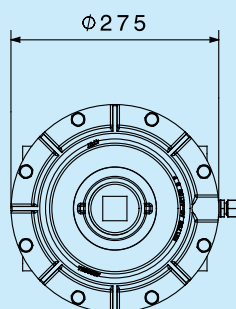

$P_d < 750$ mbar*

16kg
PN16

A=408mm
B=115mm
L=250mm

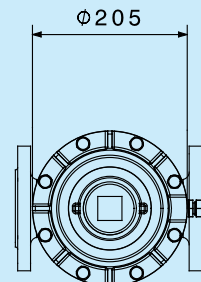

*for higher pressure high pressure shaft

R 101 DN 65

$P_e = P_u$ max. 4 bar
 $P_a = P_d$ 8-1.200mbar
 Q max. 1.500 Nm³/h
 (1.800) Nm³/h

KG-Values

$V_{32,5}$ 697 Nm³/h
 $V_{42,5}$ 1.191 Nm³/h
 $V_{52,5}$ 1.818 Nm³/h

Gas characteristics:

suitable for gas of the gas families 1, 2, 3 and other neutral gaseous media.

Ambient-temperature -20...+60°C

Fitting position any

Flow speed 30m/s
 (limit 60m/s)

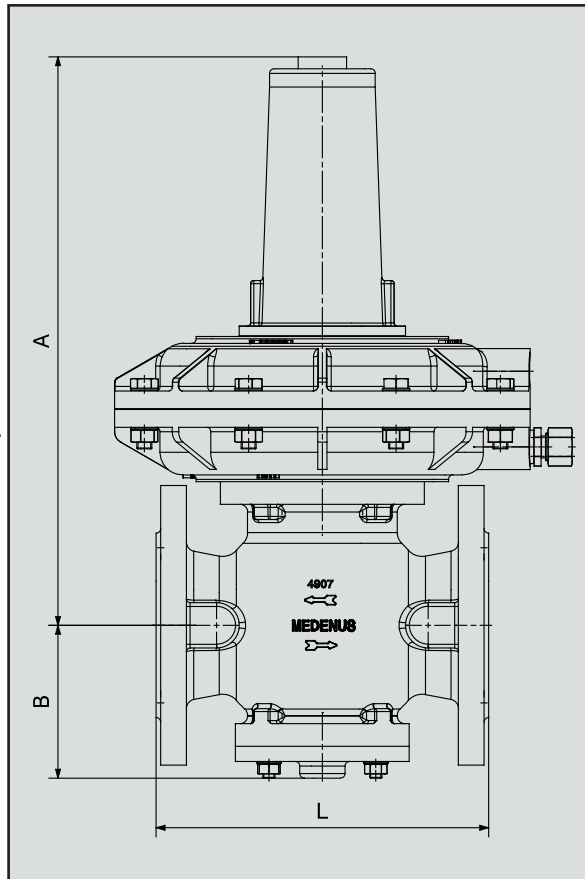

Special design:
 high pressure shaft

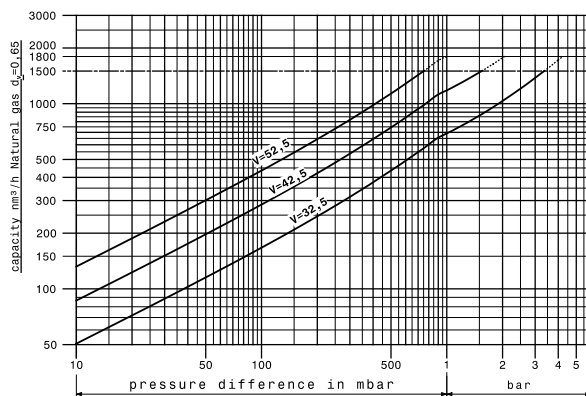

$P_d < 100$ mbar*

19kg
PN16

$A=376$ mm
 $B=101$ mm
 $L=220$ mm

$\phi 385$

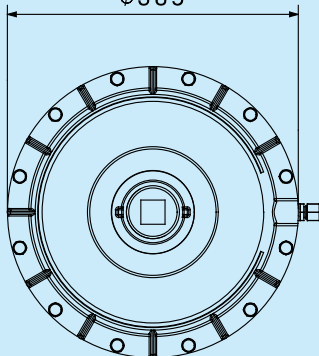

$P_d < 400$ mbar*

15kg
PN16

$A=376$ mm
 $B=101$ mm
 $L=220$ mm

$\phi 275$

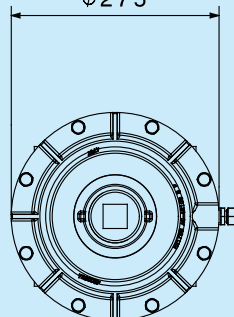

$P_d < 750$ mbar*

13kg
PN16

$A=376$ mm
 $B=101$ mm
 $L=220$ mm

$\phi 205$

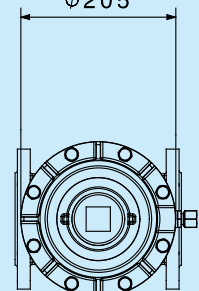

*for higher pressure high pressure shaft

R 101 DN 100

$P_e = P_u$ max. 4 bar
 $P_a = P_d$ 8-1.200mbar
 Q max. 4.000 Nm³/h
 (5.400) Nm³/h

KG-Values

V 65 2.566 Nm³/h
V 95 5.482 Nm³/h

Gas characteristics:

suitable for gas of the gas families 1, 2, 3 and other neutral gaseous media.

Ambient-temperature -20...+60°C

Fitting position any

Flow speed 30m/s
 (limit 60m/s)

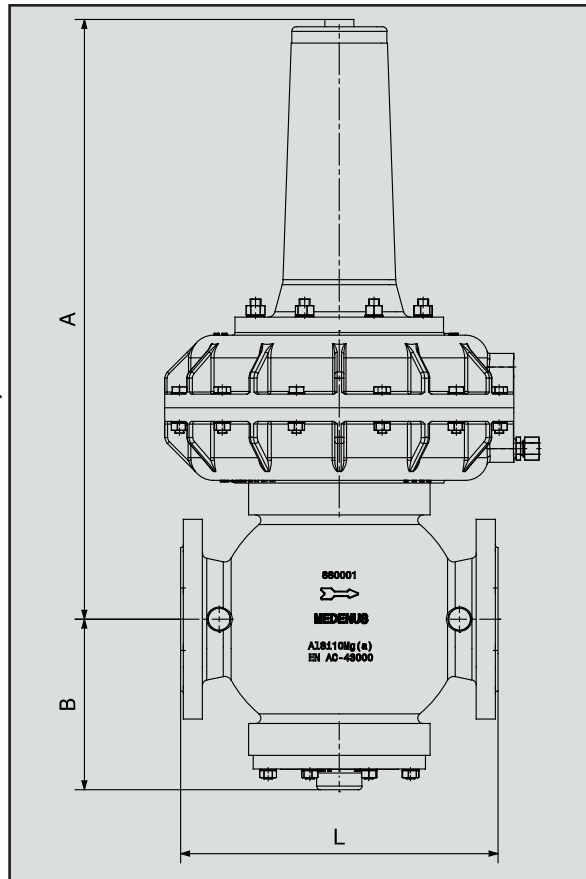

Special design:
 high pressure shaft

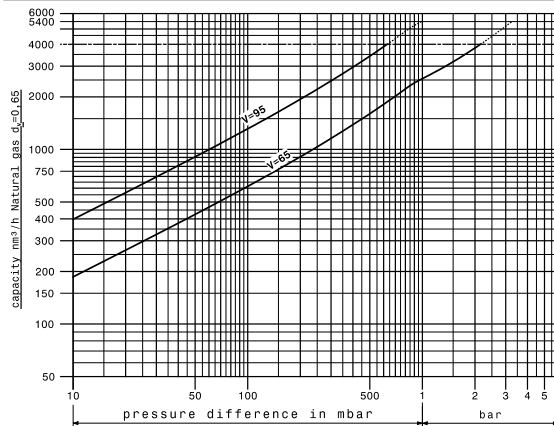

P_d < 150 mbar*

53kg
PN16

A=661mm
B=188mm
L=350mm
 Ø 485

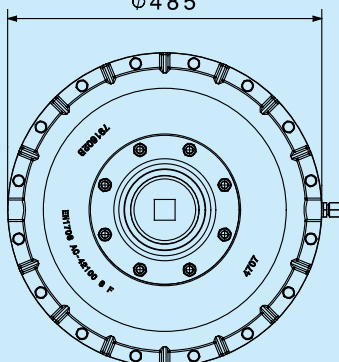

P_d < 350 mbar*

43kg
PN16

A=661mm
B=188mm
L=350mm
 Ø 385

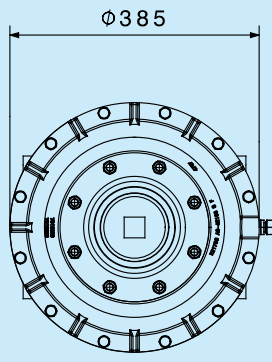

P_d < 750 mbar*

38kg
PN16

A=675mm
B=188mm
L=350mm
 Ø 275

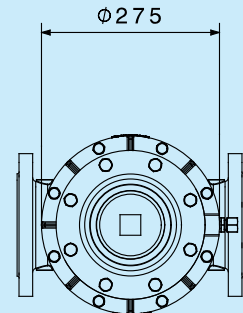

*for higher pressure high pressure shaft